

Q1471

1

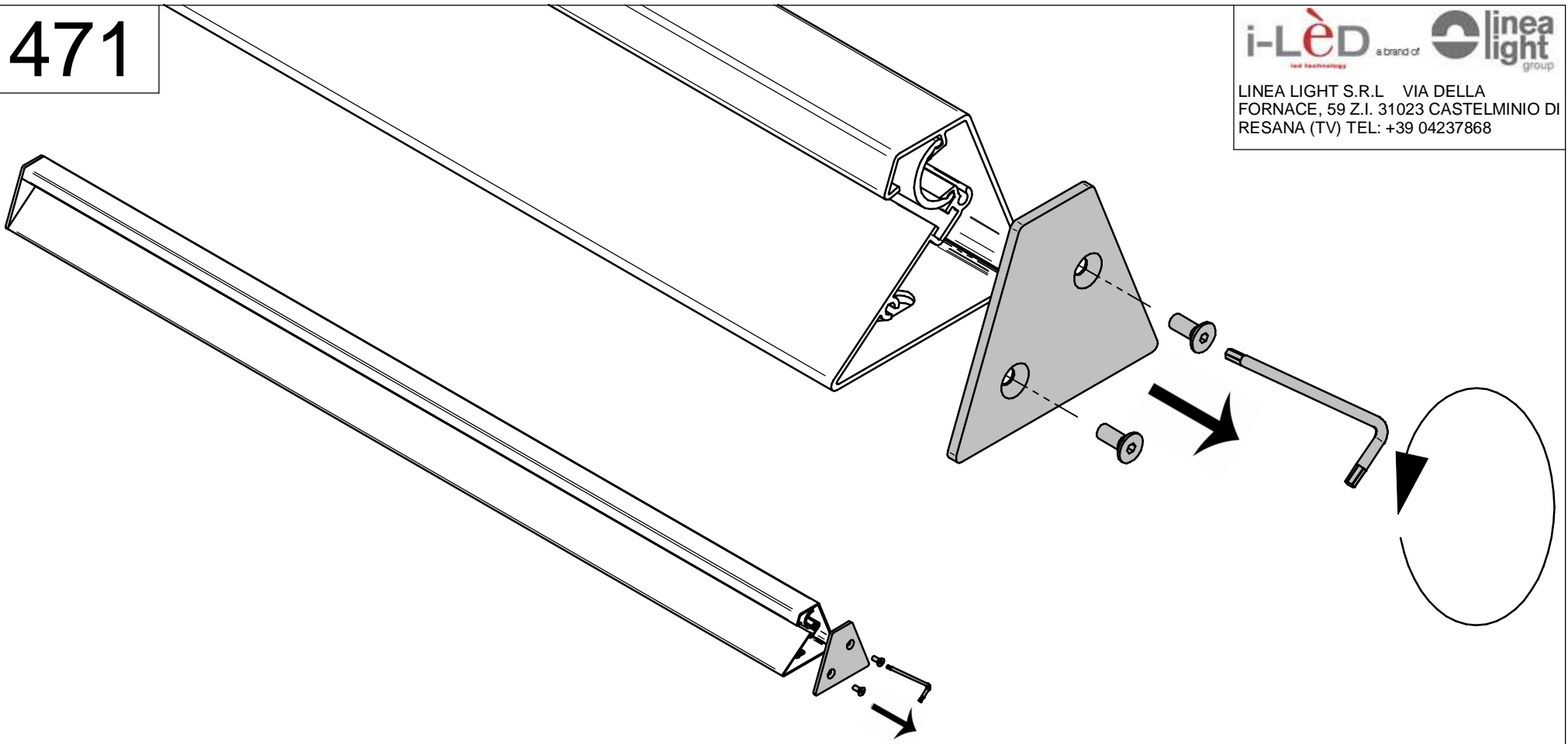

2

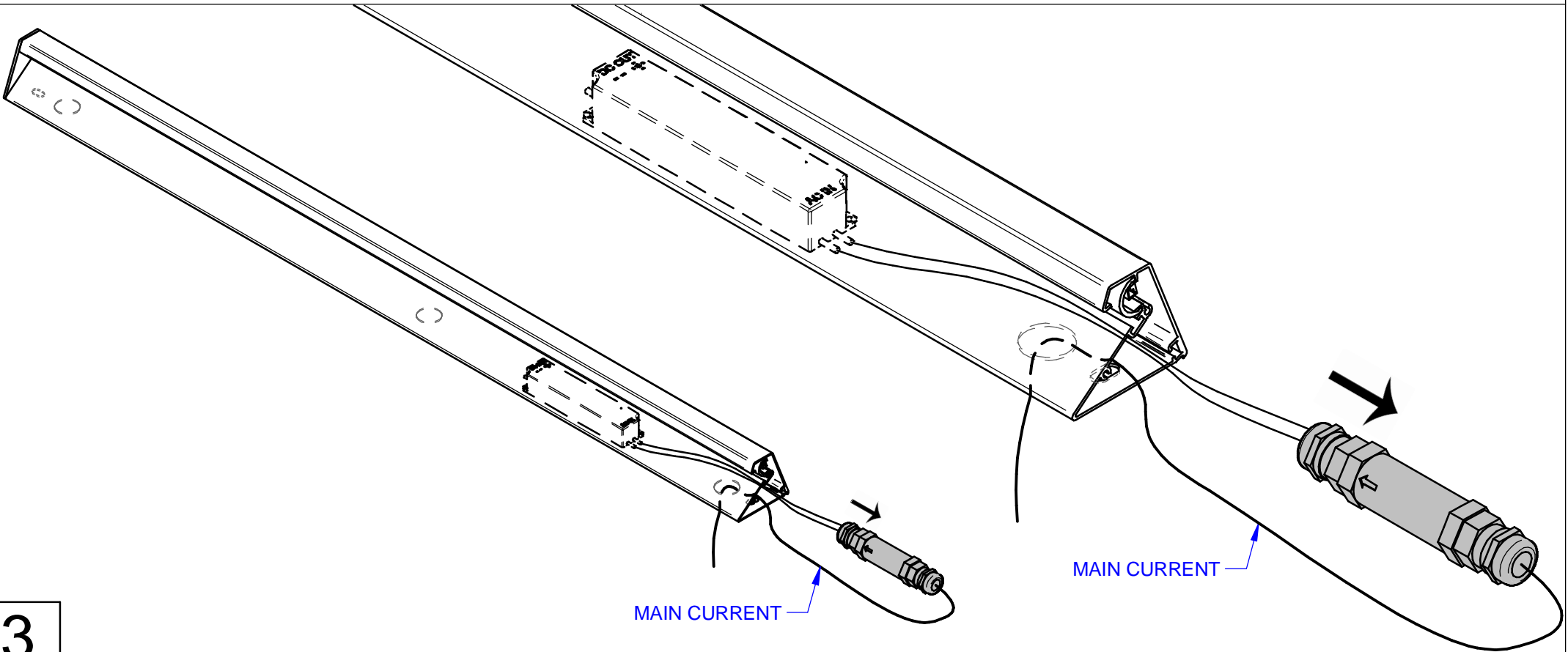
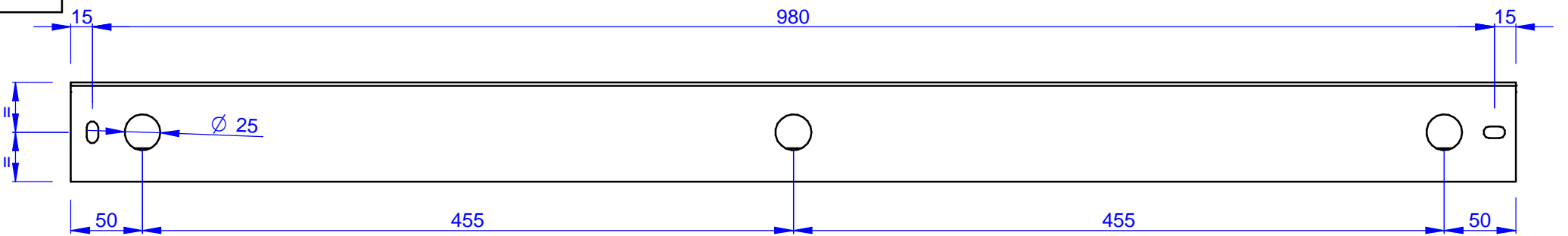

3

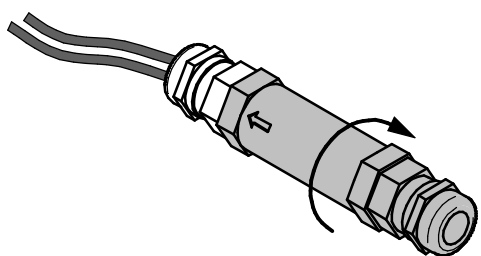

3A

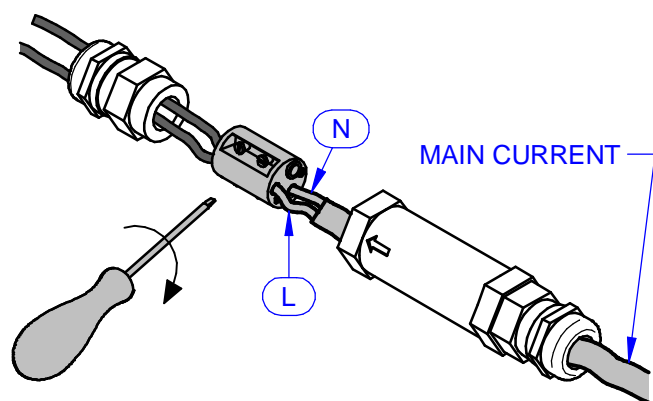

3B

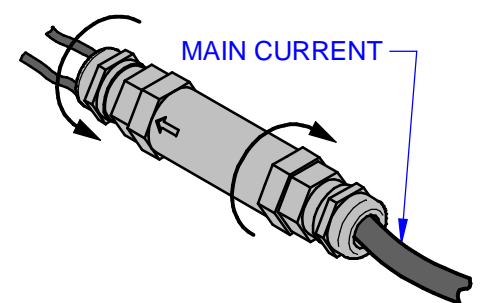

3C

Q1471

4

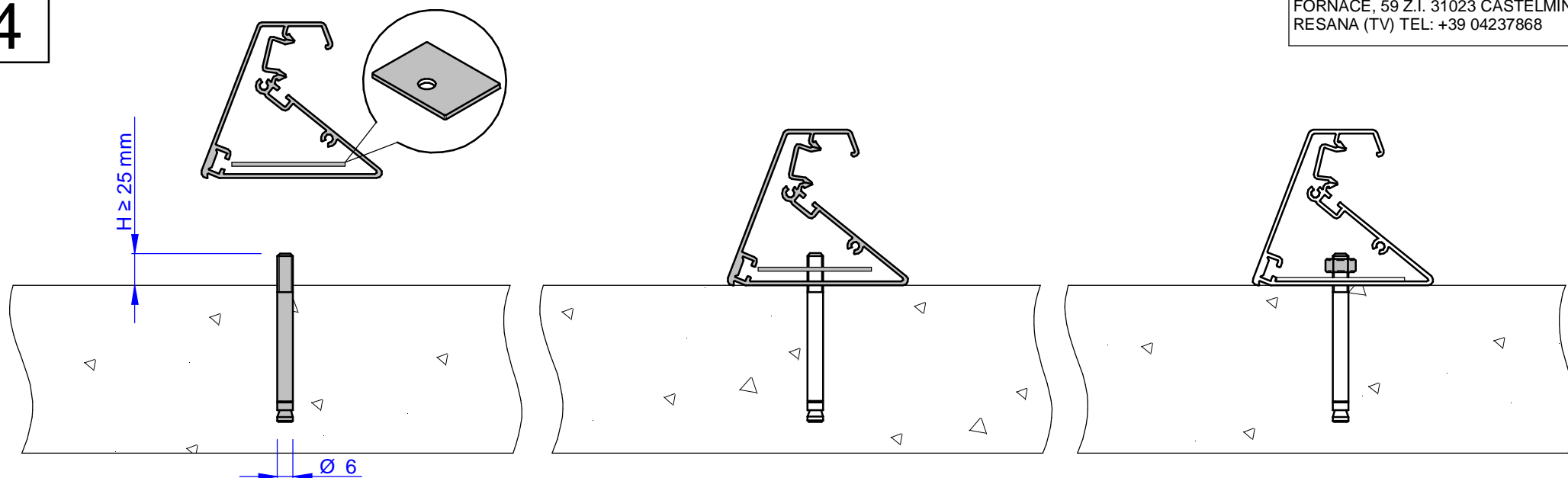

5

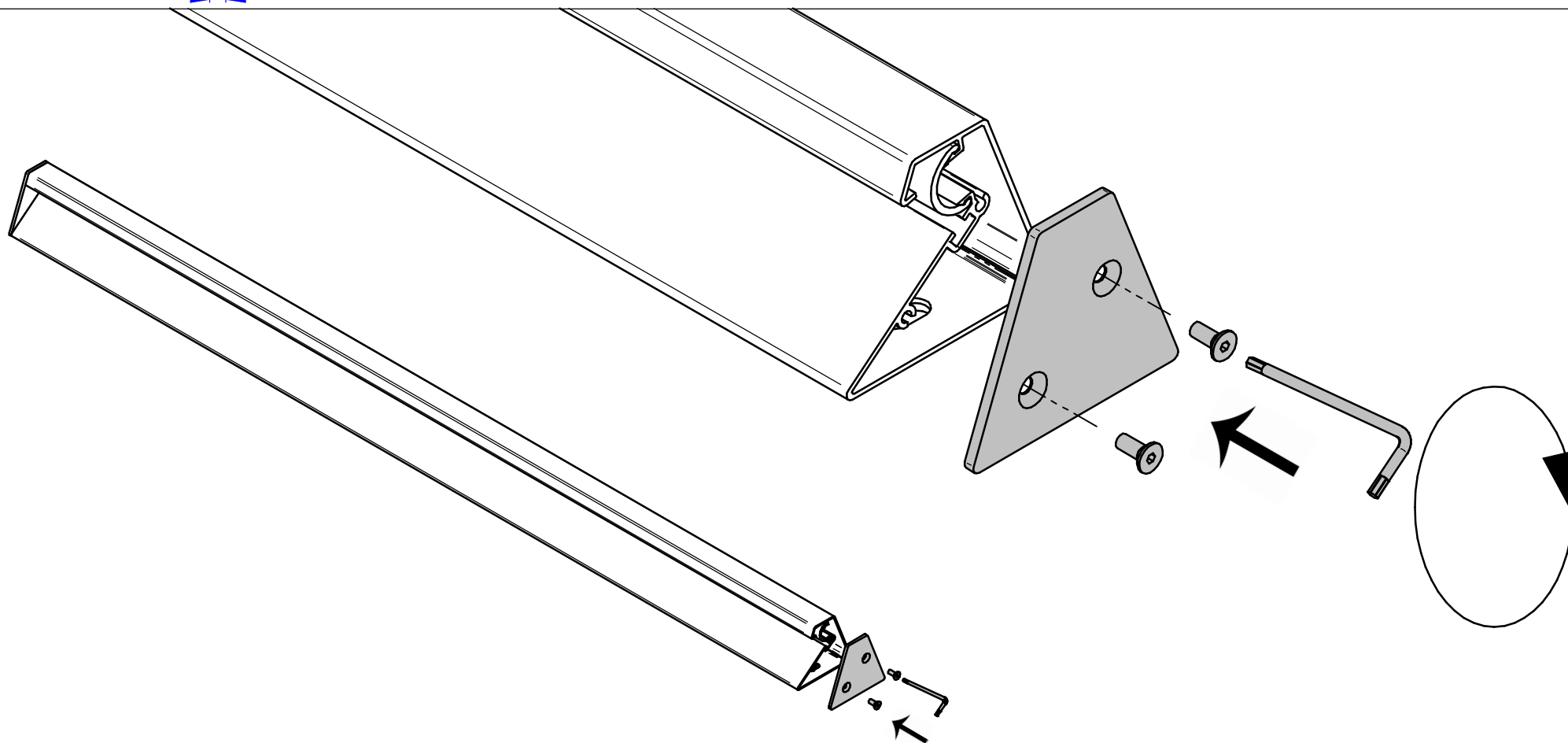

ITALIANO

ISTRUZIONI PER IL CORRETTO MONTAGGIO, UTILIZZO E MANUTENZIONE

ATTENZIONE: Queste istruzioni devono essere consultate e conservate dal personale specializzato nell'installazione e successiva manutenzione ordinaria e straordinaria. L'installazione e la manutenzione vanno effettuate ad apparecchio scollegato dalla rete dell'alimentazione. Tutte le operazioni devono essere effettuate da un tecnico specializzato. Modifiche o manomissioni del prodotto e il non rispetto delle indicazioni di seguito riportate annullano la garanzia possono rendere l'apparecchio pericoloso. L'apparecchio può raggiungere temperature elevate durante l'esercizio e pertanto occorre evitare il contatto con persone, animali o cose. La ditta TRADDEL declina ogni responsabilità per i danni causati da un proprio prodotto montato in modo non conforme alle istruzioni.

ENGLISH

INSTRUCTIONS FOR CORRECT ASSEMBLY, USE AND MAINTENANCE

WARNING: This instruction sheet must be consulted and retained by the person responsible for installation and ordinary and extraordinary maintenance. Before beginning installation or maintenance operations switch off the mains supply. All these operations must be carried out by a specialised technician. Tampering or modifying the product or failing to comply with the instructions below will void the guarantee and could render the product dangerous. Given that this fixture may reach high temperatures it is important to ensure that persons, animals or other objects do not come into direct contact with it. TRADDEL disclaims all responsibility for damage caused by products that have been not been assembled in compliance with the instructions.

