

INFORMAZIONI TECNICHE - TECHNICAL INFORMATION

Tensione nominale - Rated voltage	Vedi tabella elenco prodotti - See product list table
Frequenza - Frequency	50/60Hz
Classe di isolamento - Insulation class	Vedi tabella elenco prodotti - See product list table
Temperatura ambiente di utilizzo - Ambiente temperature for using	-20°C ÷ +50°C
Grado di protezione - Degree of protection	IP 67
Potenza - Power	Vedi tabella elenco prodotti - See product list table

Installazione / Manutenzione - Installation / Maintenance

L'articolo dovrà essere installato da personale qualificato, **seguendo le normative d'installazione vigenti del paese di appartenenza**; in caso di malfunzionamento o necessità di manutenzione della plafoniera contattare il servizio clienti LINEA LIGHT: support@linealight.com.

È VIETATO APRIRE/ TOCCARE L'ARTICOLO MENTRE È IN FUNZIONE;

Qualora non vengano rispettate le regole indicate, **l'azienda LINEA LIGHT declina ogni tipologia di responsabilità.**

The item must be installed by qualified personnel, **in accordance with the installation regulations in force in the country in question**; in case of ceiling light malfunction or need for maintenance contact LINEA LIGHT customer service:

support@linealight.com.

IT IS FORBIDDEN TO OPEN/TOUCH THE ITEM WHILE IT IS IN OPERATION;

If the indicated rules are not respected, **the LINEA LIGHT company declines any type of responsibility.**

UTILIZZO CONFORME:

L'apparecchio è garantito esclusivamente se l'articolo in questione sia stato installato seguendo le istruzioni riportate in questo manuale istruzioni e da quello generale presente all'interno dell'imballo e/o scaricabile dal nostro sito www.linealight.com;

Un utilizzo scorretto dell'apparecchio può influire sulla durata utile della lampada e/o potrebbe avere un guasto precoce.

Per ulteriori avvertenze e spiegazione di eventuali simboli vedere il foglio istruzioni generale.

Conservare le presenti istruzioni per futuri lavori di installazione/manutenzione.

APPROPRIATE USE:

The appliance is guaranteed only if the item in question has been installed following the instructions given in this instruction manual and from the general one inside the packaging and/or downloadable from our website www.linealight.com;

Improper use of the fixture may affect the lamp life and/or may have premature failure.

For further warnings and explanation of any symbols, see the general instruction sheet.

Keep these instructions for future installation/maintenance work.

(ITA) - I prodotti devono essere installati tassativamente con alimentazioni, cablaggi e accessori originali del Gruppo Linea Light, o eventualmente approvati dall'azienda. L'utilizzo di accessori non originali, o non approvati, determina il decadimento di ogni garanzia sul prodotto. (ENG) - All power supply, wiring and accessories used for product installation shall be original Linea Light Group parts or approved by the company. The warranty will become void if non original or non approved parts are used. (FRA) - Les produits doivent impérativement être installés avec des alimentations, des câblages et des accessoires Linea Light Group, ou qui ont été approuvés par l'entreprise. L'utilisation d'accessoires non d'origine, ou non approuvés, entraîne la déchéance de toute garantie sur le produit. (ESP) - Los productos se han de instalar obligatoriamente con alimentaciones, cableados y accesorios originales de Linea Light Group o, de otra forma, deben ser aprobados por la empresa misma. El uso de accesorios no originales, o no aprobados, anula todas las garantías del producto. (GER) Die Produkte müssen obligatorisch mit Originalstromversorgung, Originalkabeln und Originalzubehör der Linea Light Group oder mit Teilen, die von der Linea Light Group ausdrücklich empfohlen sind, installiert werden. Die Verwendung von nicht originale oder nicht vom Hersteller empfohlenem Zubehör führt zu einem sofortigen Verfall vom Garantieanspruch für das Produkt.

SERIE / SERIES: ORMA-I / ORMA-IL / ORMA-C

BRAND: i-LèD

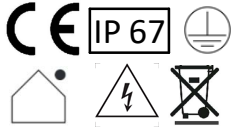

ELENCO ARTICOLI

LIST OF FIXTURES

CODE	D (mm)	POWER	INPUT	WEIGHT
76080	97	7W AC	198-264 VAC	0,5Kg
76081				
76180				
76082	138	11,5W AC	198-264 VAC	0,5Kg
76181		7W AC		
76083				

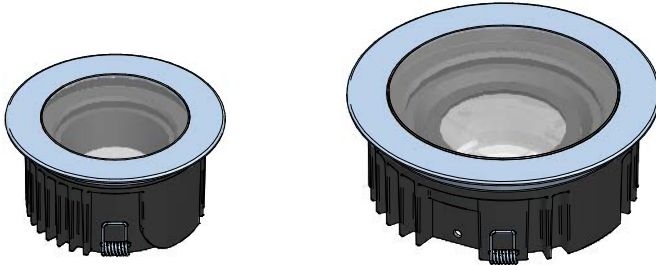

**ACCESSORI NON INCLUSI
ACCESSORIES NOT INCLUDED**

A. CONTROCASSA PER ORMA-I/ORMAIL D.97
A. OUTERCASING FOR D.97 ORMA-I/ORMAIL
CODE: 99651

B. CONTROCASSA PER ORMA-I/ORMAIL D.138
B. OUTERCASING FOR D.138 ORMA-I/ORMAIL
CODE: 99652

C. CONTROCASSA PER ORMA-C SU MURATURA
C. OUTERCASING FOR ORMA-C ON CONCRETE
D97 CODE: 89373
D138 CODE: 99749 + 99750

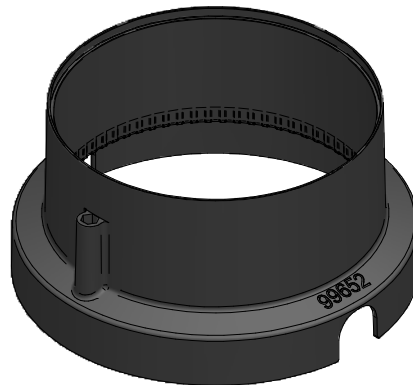
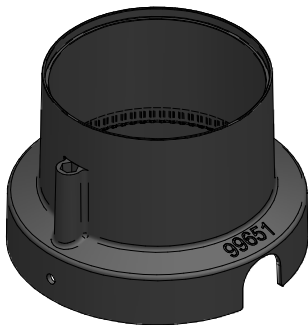

**DIMENSIONI
DIMENSIONS**

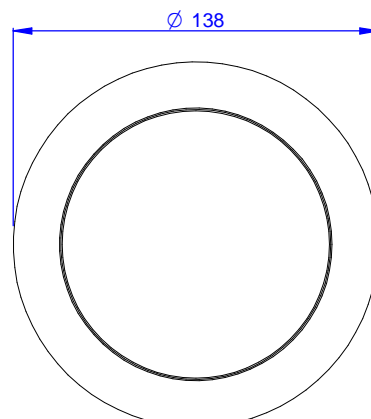
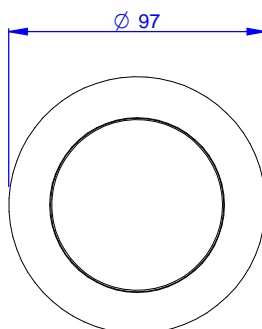
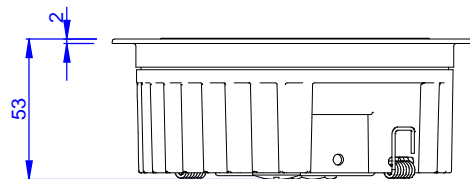
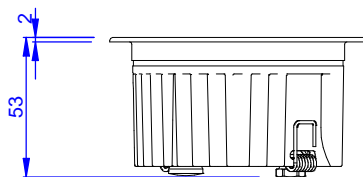

INSTALLAZIONE ORMA-I/ORMA-IL ORMA-I/ORMA-IL INSTALLATION

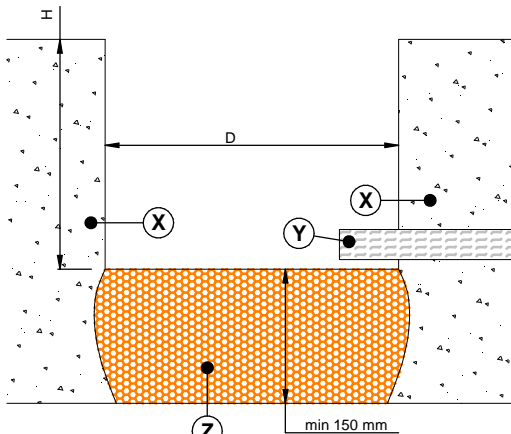

ART.		MEDIUM	BIG
ORMA_I, ORMA_IL	CODE	99651	99652
	D (mm)	114	154
	H (mm)	76	

(X) CEMENTO ESISTENTE*
EXISTING CONCRETE*

(Y) TUBO CORRUGATO
CORRUGATED TUBE

(Z) DRENAGGIO
DRAINAGE

* CONDIZIONE NON VINCOLANTE
* NOT BINDING CONDITIONS

1 POSIZIONARE LA CONTROCASSA E BLOCCARLA CON CEMENTO / PLACED THE OUTERCASING AND FIXED WITH CONCRETE

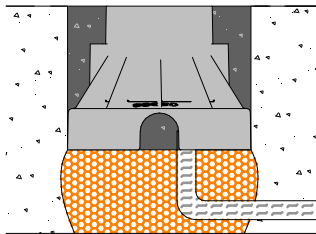

2 CABLARE (IP68), RUOTARE LE MOLLE ED INSERIRE IL FARO NELLA CONTROCASSA / WIRED (IP68), ROTATE THE SPRINGS AND PLACED THE SPOTLIGHT INTO THE OUTERCASING

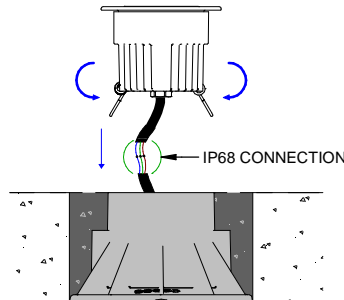

3 INSTALLAZIONE COMPLETATA / INSTALLATION COMPLETED

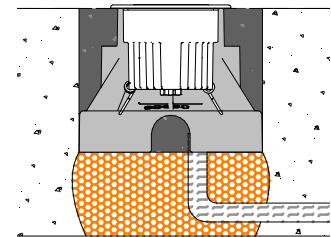

INSTALLAZIONE ORMA-C SU CONTROSOFFITTO ORMA-C INSTALLATION ON CEILING

Art.	A	h
ORMA_C 8 W	ø 86 mm	5-20mm
ORMA_C 13 W	ø 127 mm	5-20mm

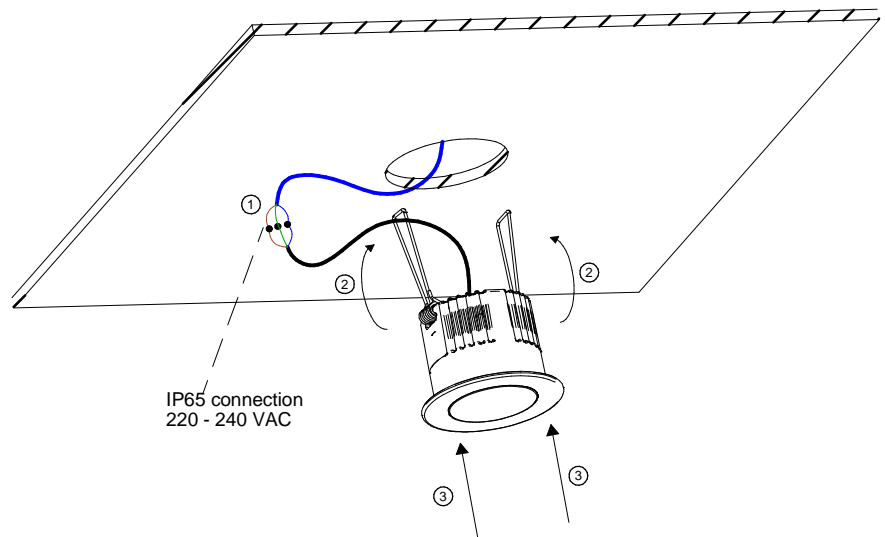
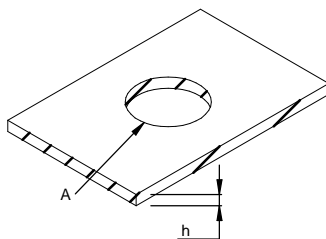

(ITA) - Distanza minima consigliata da soffitto / isolante
(ENG) - Recommended minimum distance from ceiling / insulator

N.B.

(ITA) - Non coprire l'articolo con materiale isolante.
(ENG) - Do not cover the product with insulating material.

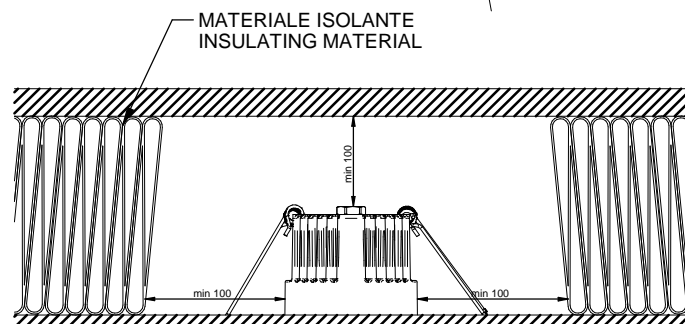

**INSTALLAZIONE ORMA-C SU MURATURA
ORMA-C INSTALLATION ON CONCRETE**

Art.	OUTERCASING	HOLE
ORMA_C 8 W	89373	Ø86mm
ORMA_C 13 W	99749 + 99750	Ø127mm

CODE: 89373

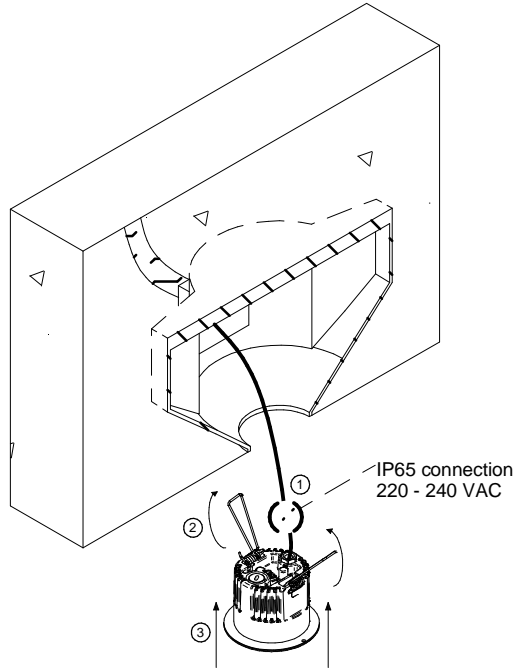
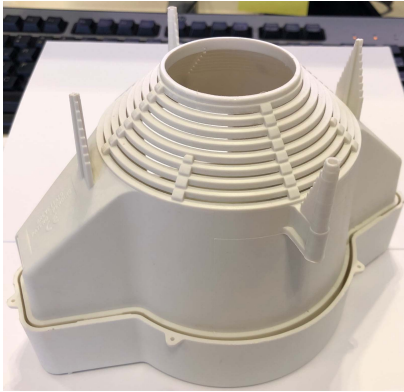

CODE: 99749

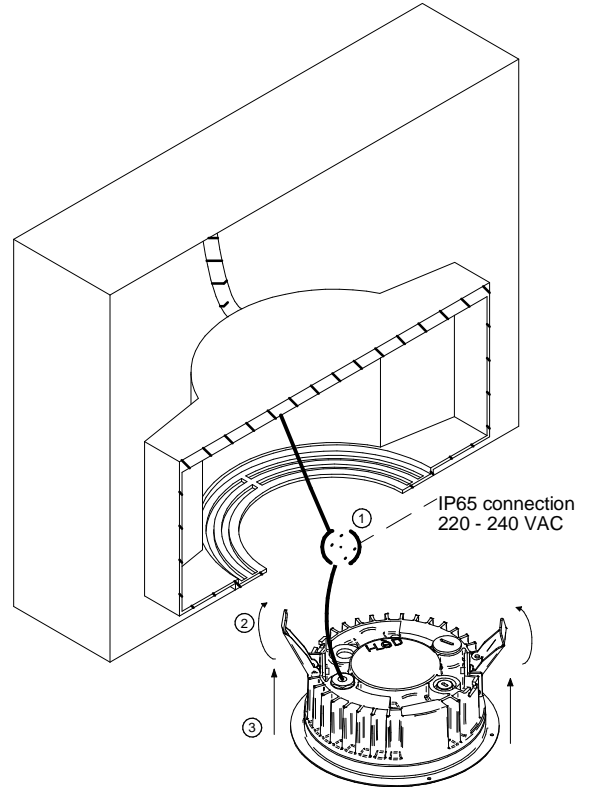
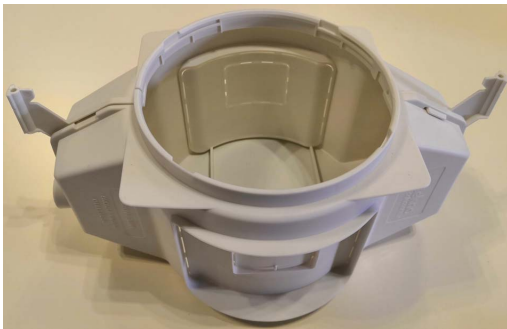

CODE: 99750



**TAGLIARE A Ø127mm /
CUT TO Ø127mm**

CABLAGGIO / WIRING

Collegamento diretto alla linea elettrica
Directo connection to the main

ON-OFF 198-264VAC
50-60 Hz

