

**Serie : Modus\_M - Microprismatic - Oputs\_EX - Projectors - Cell\_WW - Cell - Tamponamento Inferiore**  
**83722 - 83746 - 83760 - 83723 - 83747 - 83761 - 83724 - 83748 - 83762 - 83732 - 83756**  
**83731 - 83755 - 83730 - 83754 - 83721 - 83745 - 83720 - 83744 - 83725 - 83749 - 83729**  
**83753 - 83726 - 83750 - 83727 - 83751 - 83728 - 83752**

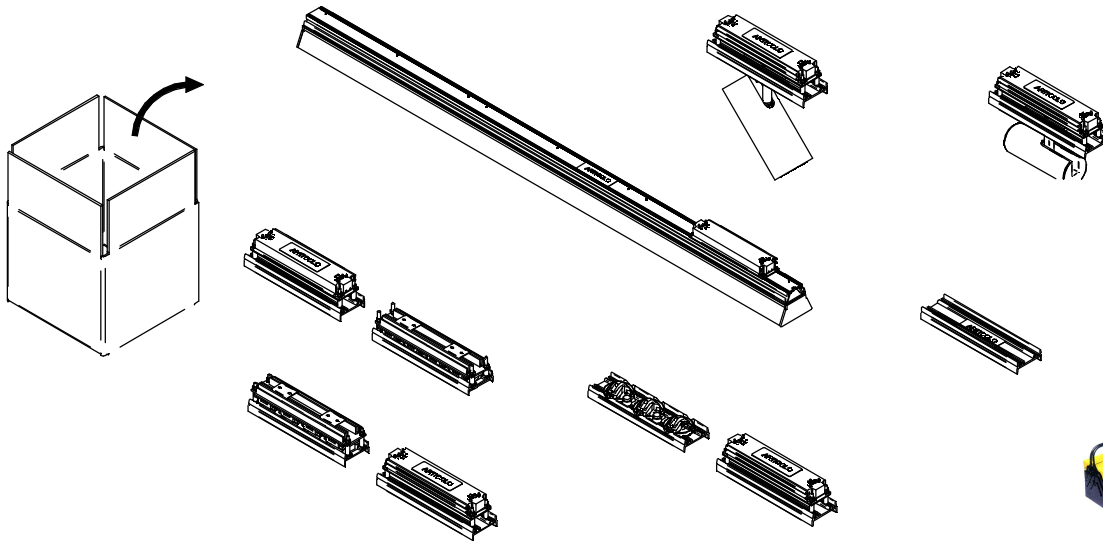

Etichetta energetica scaricabile dal sito [www.linealight.com](http://www.linealight.com)  
 Energy label downloaded from the website [www.linealight.com](http://www.linealight.com)



L'APPARECCHIO DEVE ESSERE INSTALLATO DA PERSONALE QUALIFICATO. L'AZIENDA DECLINA OGNI RESPONSABILITÀ QUALORA L'INSTALLAZIONE NON AVVENGA LASCIARE UNA COPIA DI QUESTE ISTRUZIONI AL RESPONSABILE DELLA MANUTENZIONE. CONSERVARE L'ETICHETTA DELL'IMBALLO ORIGINALE PER EVENTUALI RECLAMI FUTURI

THIS FIXTURE MUST BE INSTALLED BY A QUALIFICATED ELECTRICIAN. LINEA LIGHT IS NOT RESPONSABLE IF ITS FIXTURES ARE NOT INSTALLED ACCORDING TO LOCAL SAFETY STANDARDS. PLEASE LEAVE A COPY OF THESE INSTRUCTIONS TO THE PERSON RESPONSABLE FOR THE MAINTENANCE OF THE INSTALLATION. KEEP THE LABEL OF THE ORIGINAL PACKING FOR THE EVENTUAL FUTURE CLAIMS.

## Product Installation

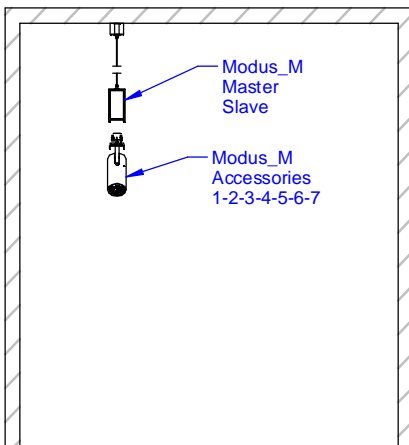

### 1) Microprismatic

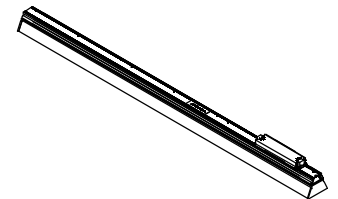

### 2) Oputs\_EX

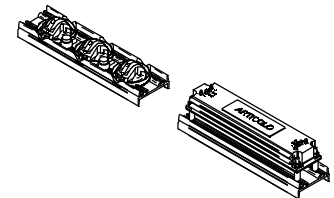

### 3) Projectors 7W

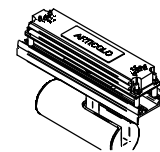

### 4) Projectors 12W

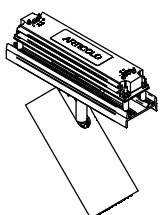

### 5) Cell\_WW

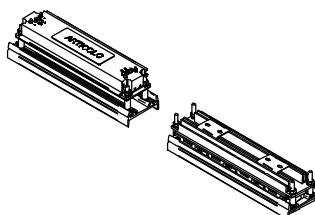

### 6) Cell

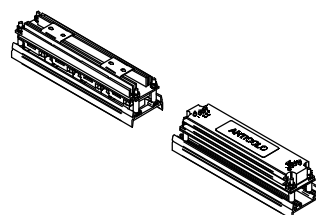

### 7) Tamponamento Inferiore

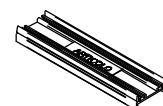

1

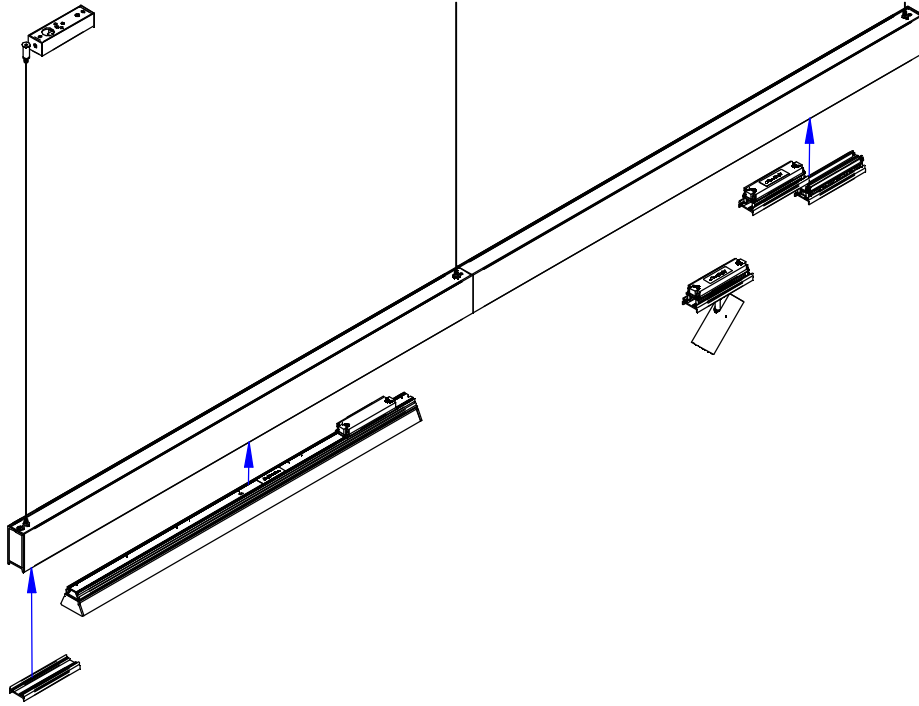

2

**MICROPRISMATIC**

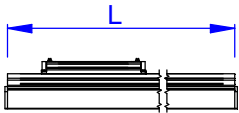

LENGTH L(mm)
900
1200
1500

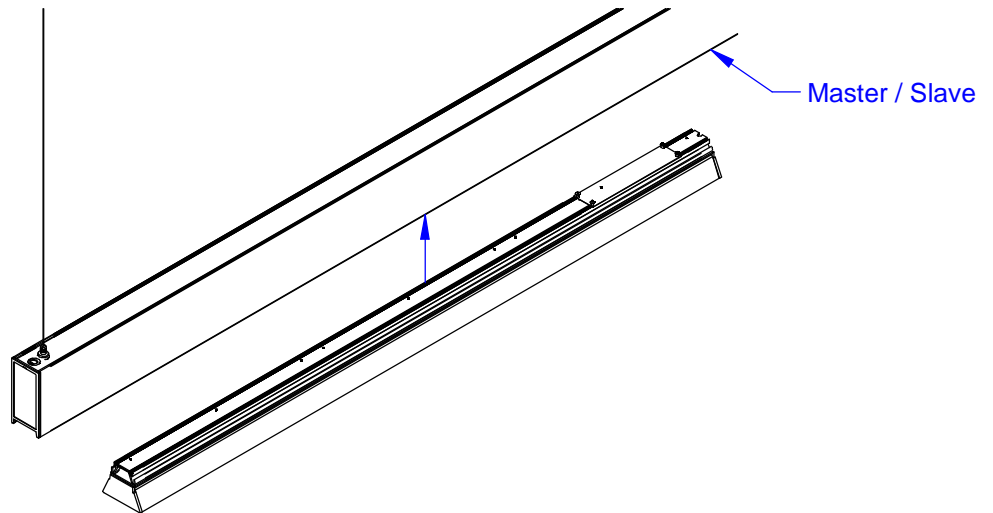

**ATTENZIONE / WARNING**

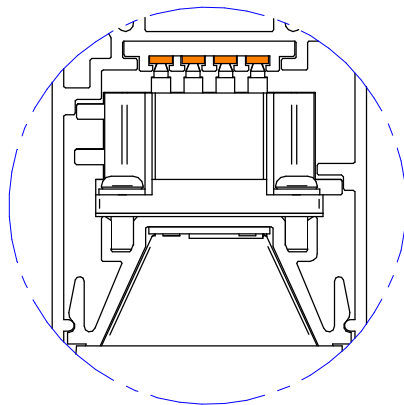
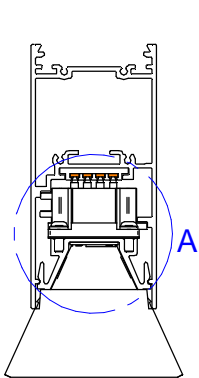

DETTAGLIO A

**SI / YES**

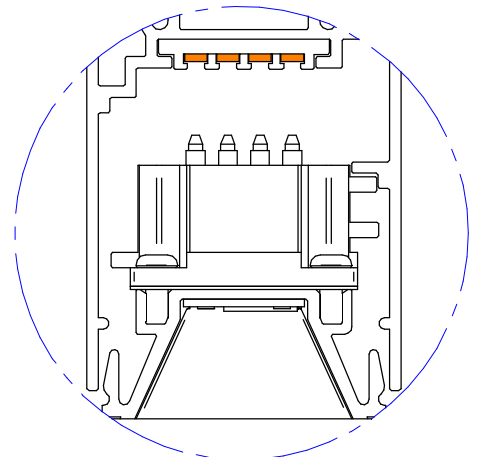
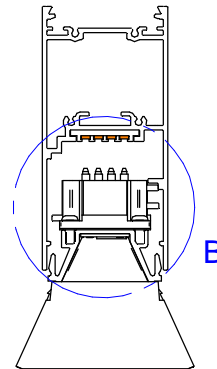

DETTAGLIO B

**NO**

**3** OPTUS\_EX

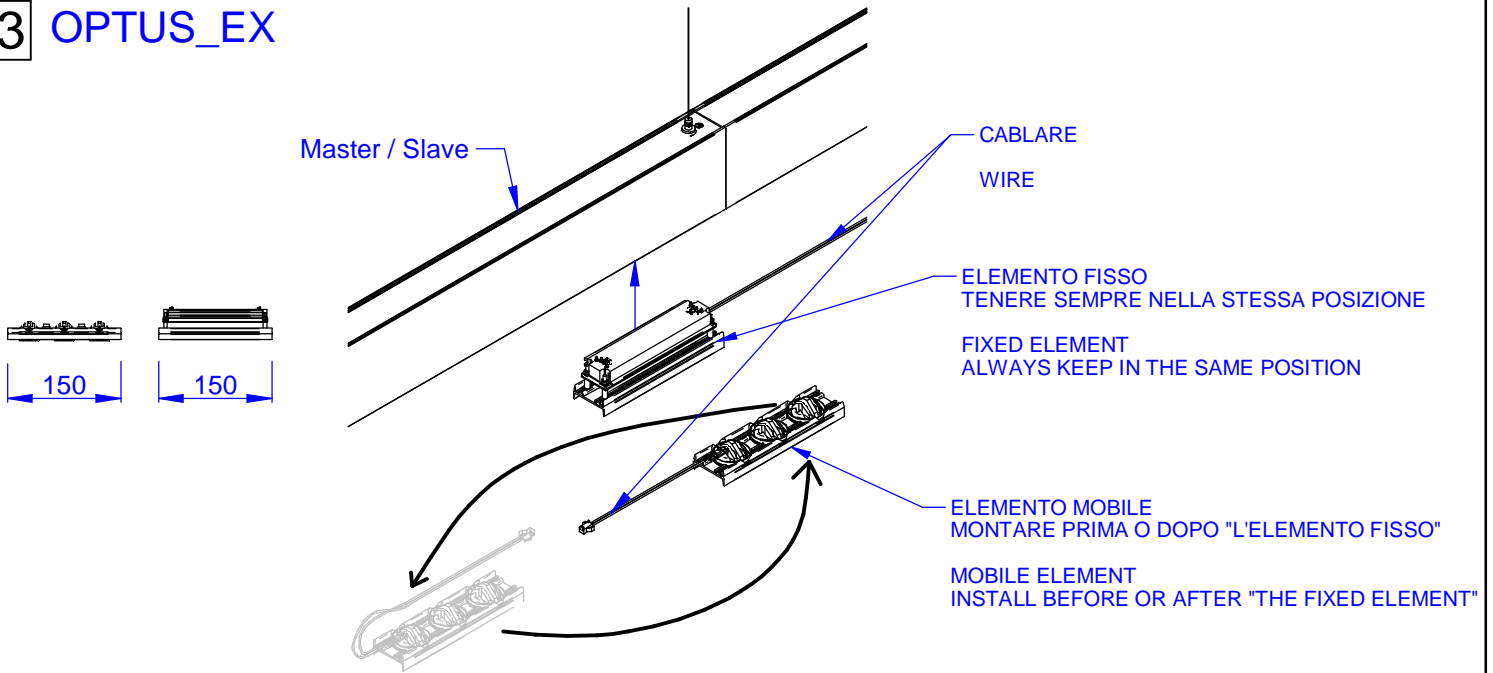

**ATTENZIONE / WARNING**

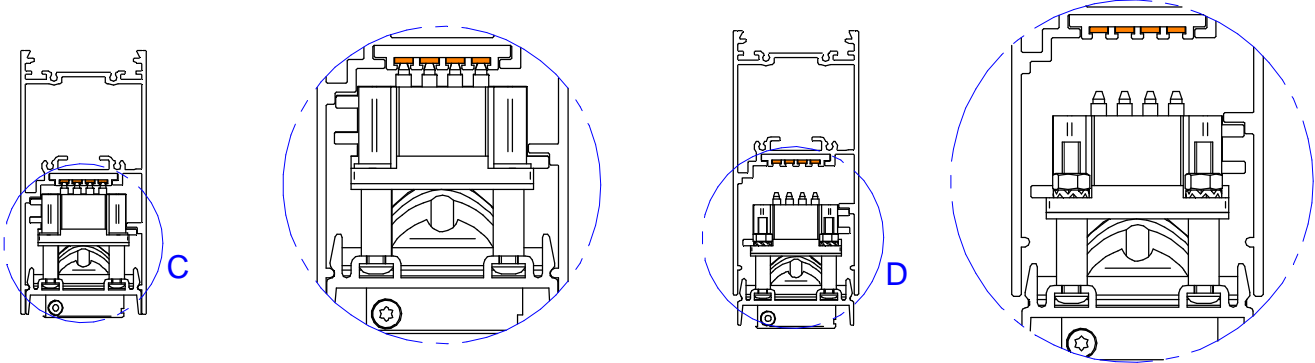

DETTAGLIO C

DETTAGLIO D

**SI / YES**

**NO**

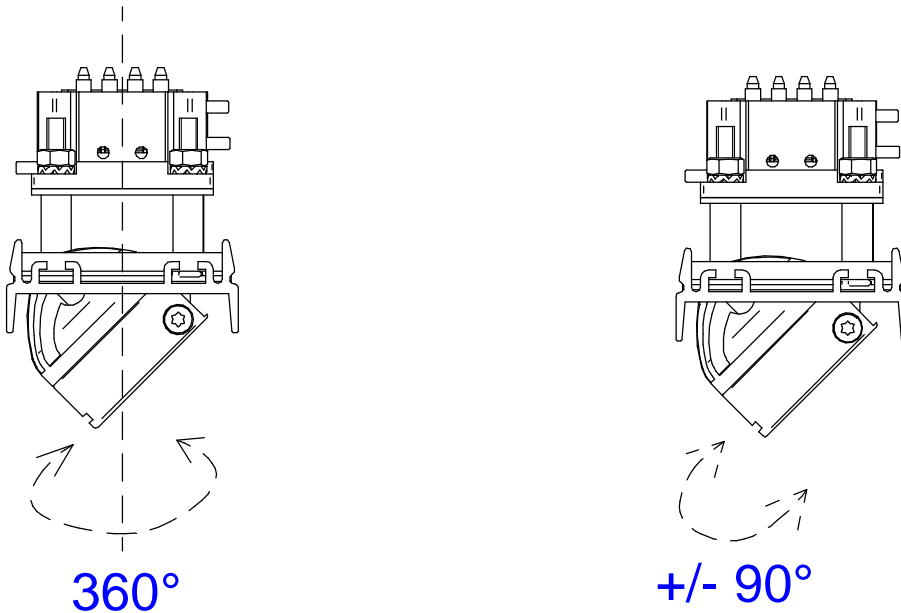

# 4 PROJECTORS 7W

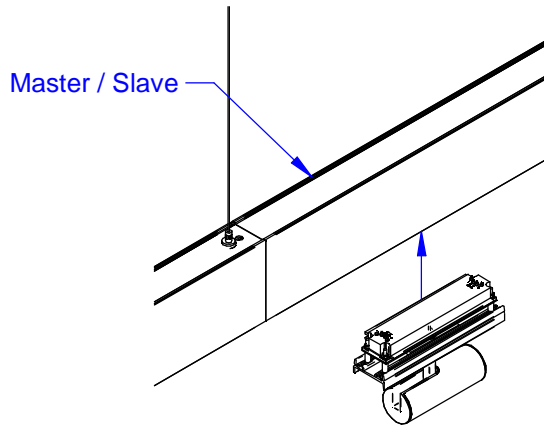
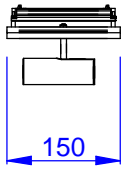

## ATTENZIONE / WARNING

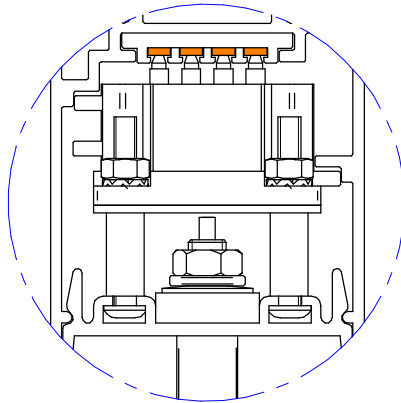
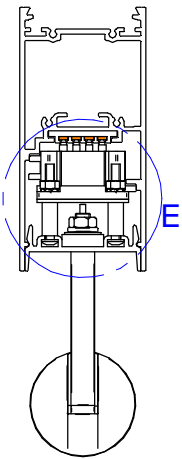

SI / YES

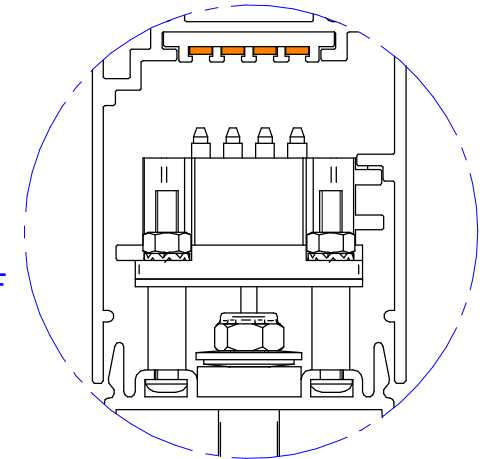
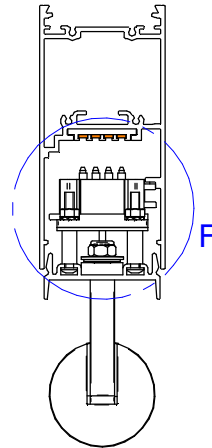

NO

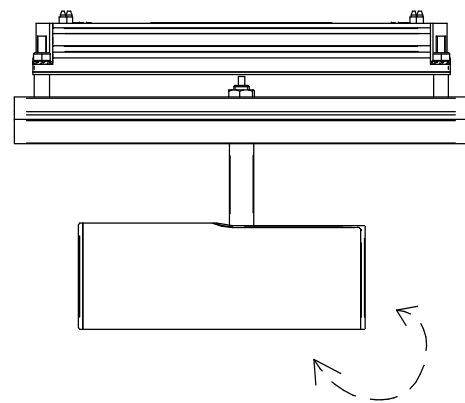
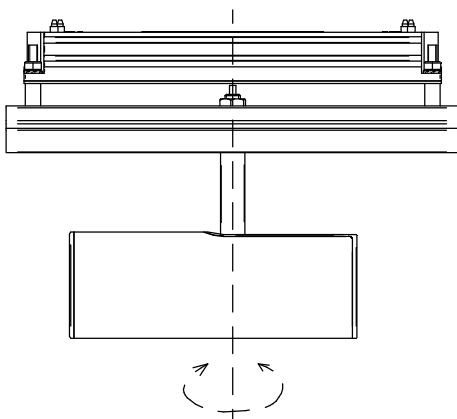

# 5 PROJECTORS 12W

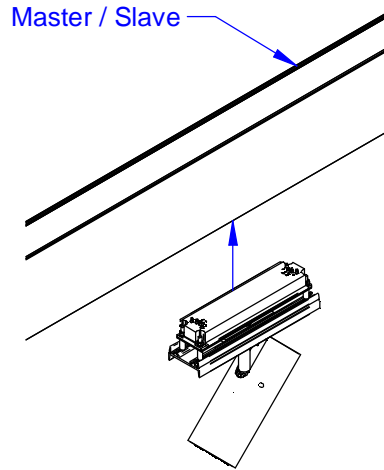
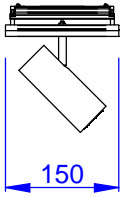

## ATTENZIONE / WARNING

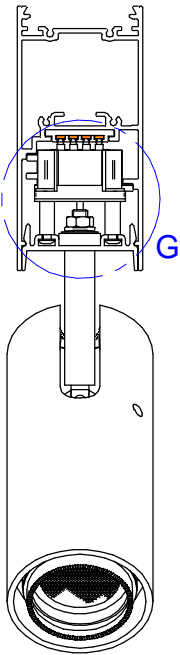

DETTAGLIO G

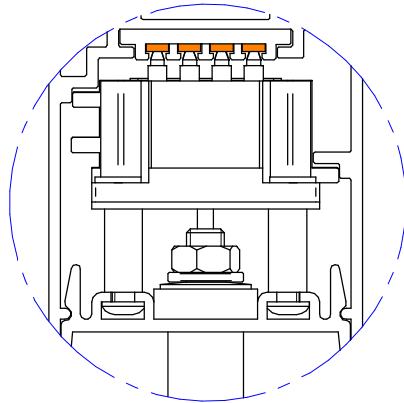

SI / YES

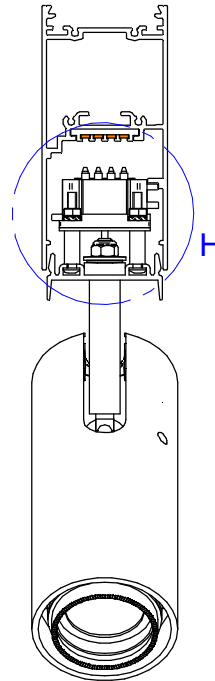

DETTAGLIO H

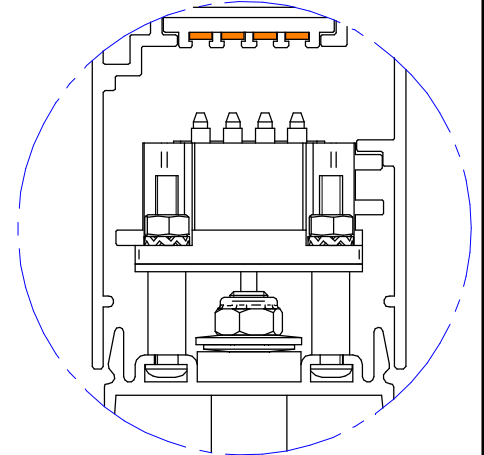

NO

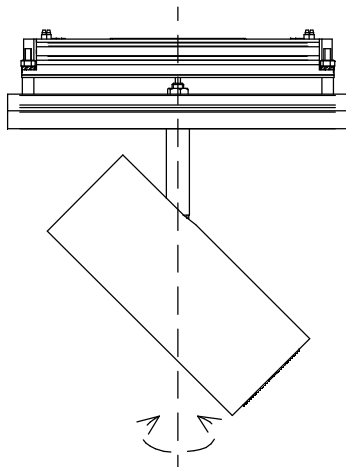

350°

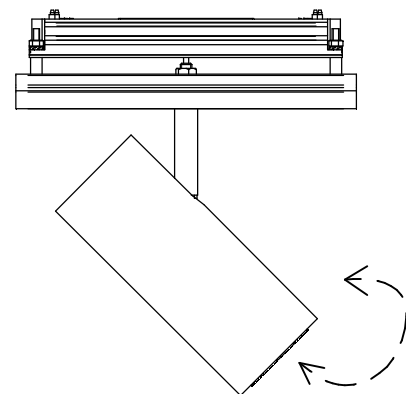

+/- 90°

**6** CELL\_WW

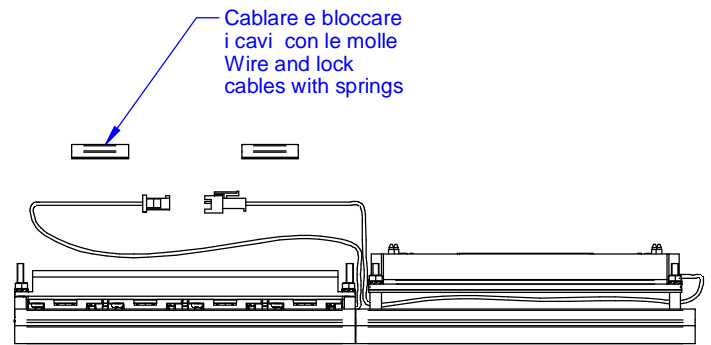
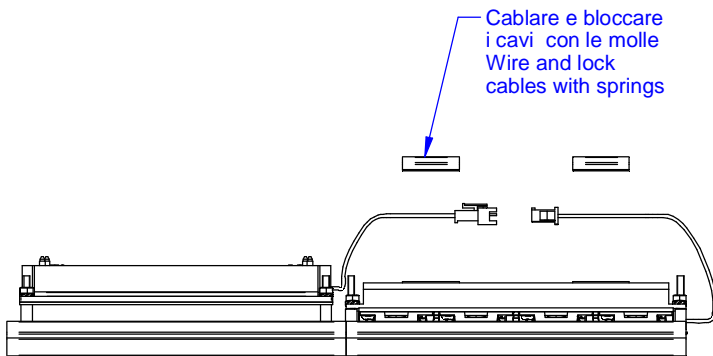
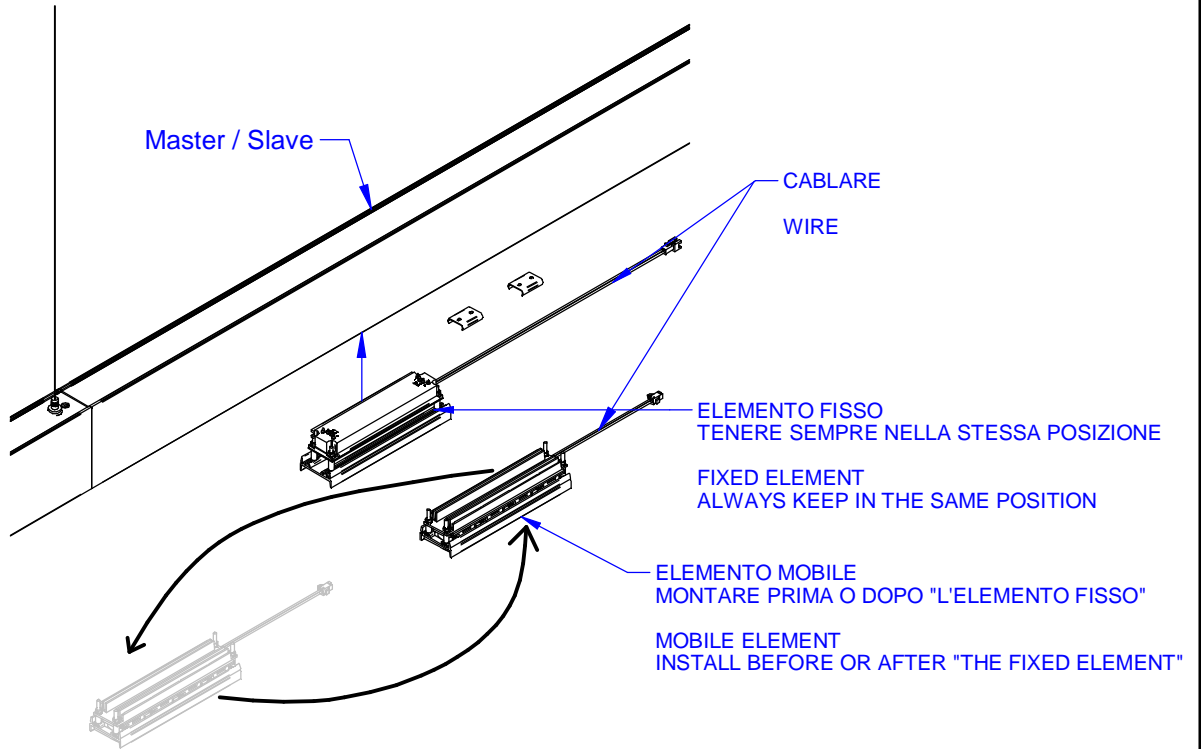
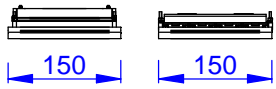

**ATTENZIONE / WARNING**

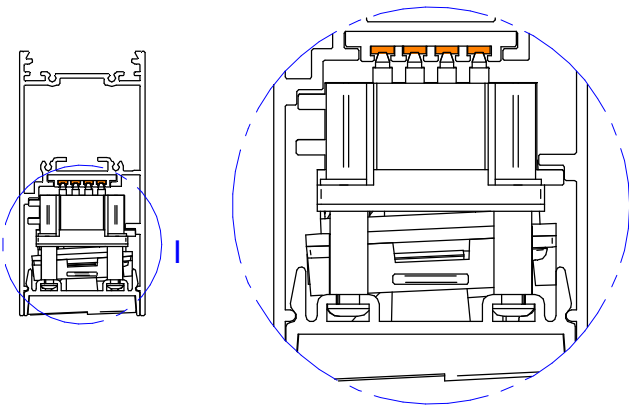

DETTAGLIO I

**SI / YES**

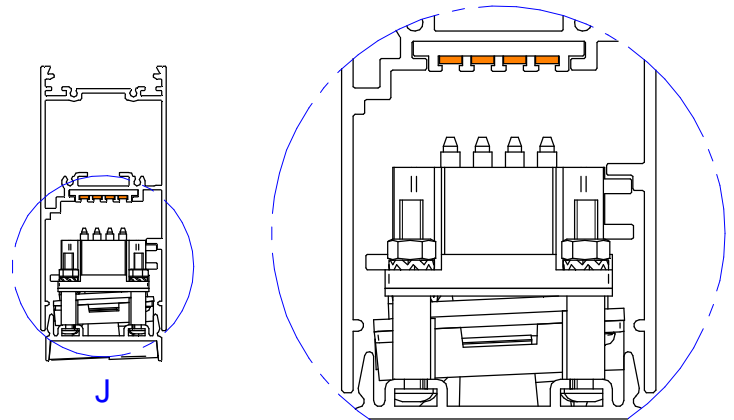

DETTAGLIO J

**NO**

**7 CELL**

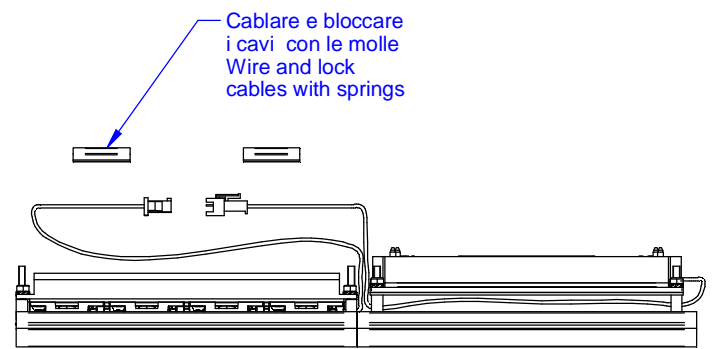
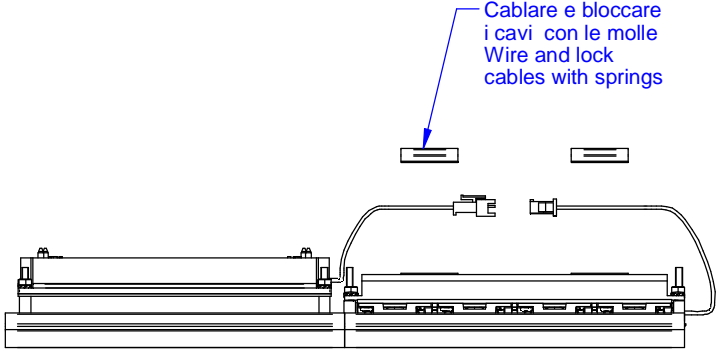
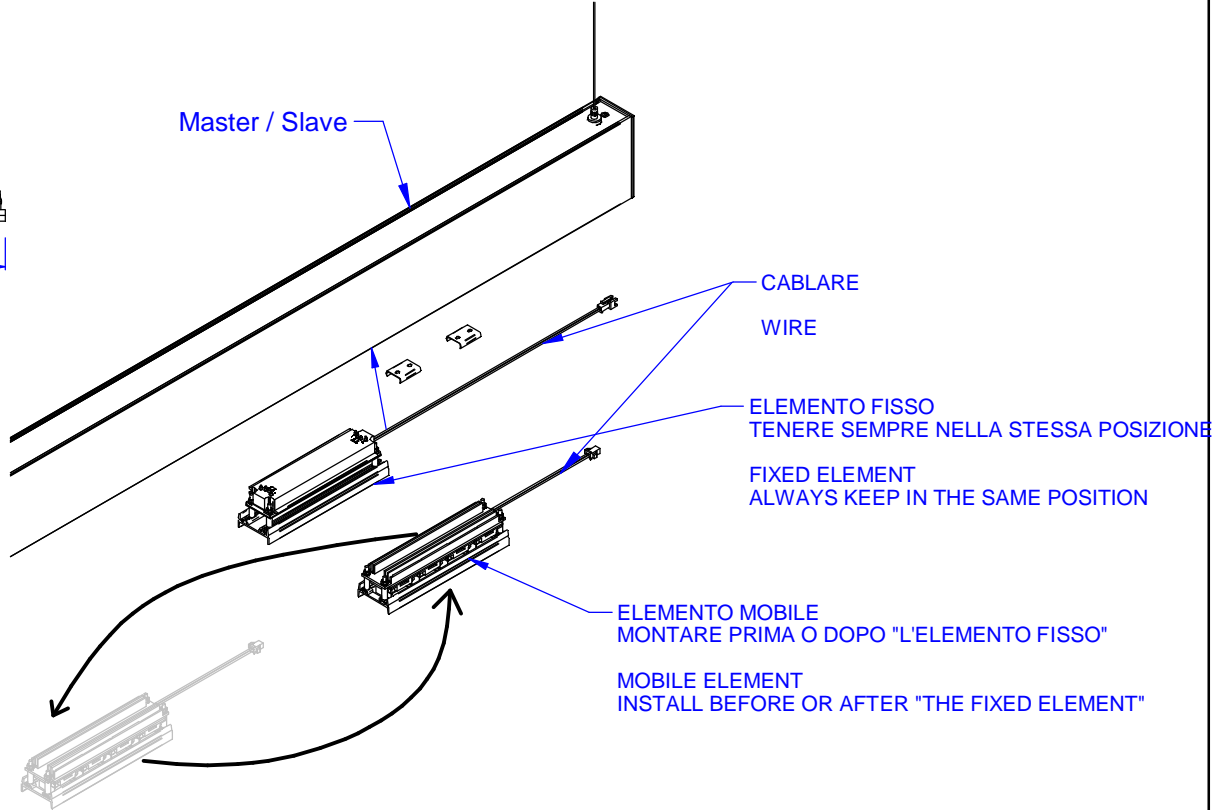
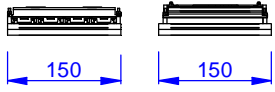

**ATTENZIONE / WARNING**

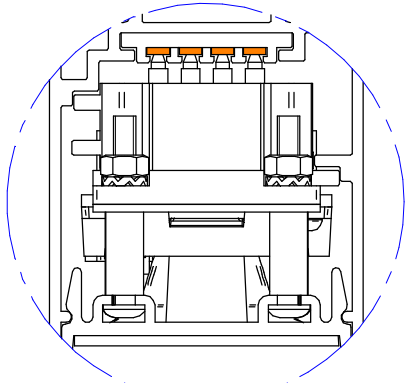
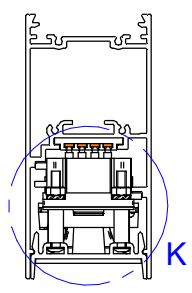

DETTAGLIO K  
**SI / YES**

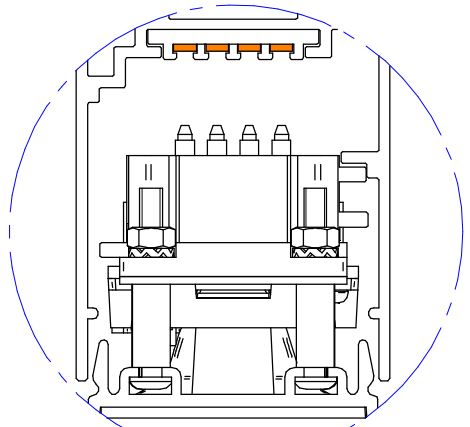
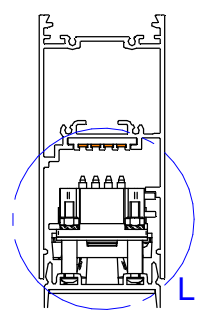

DETTAGLIO L  
**NO**

## 8 TAMPONAMENTO INFERIORE

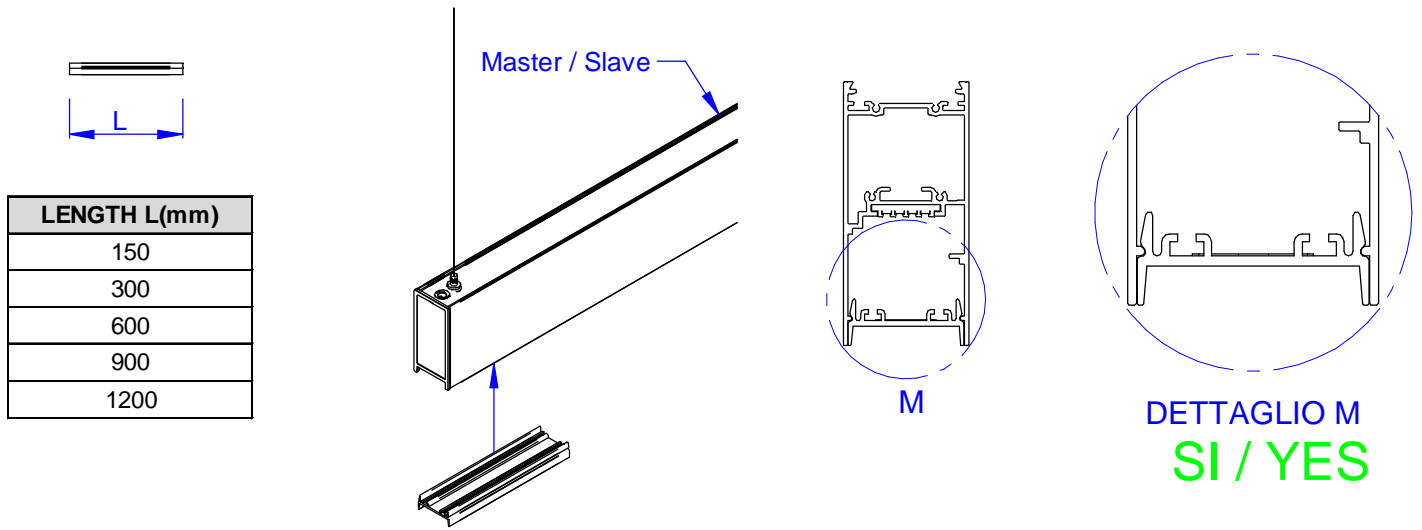

## MASTER L 1200 - 1500 MM

Rialimentare con un master ogni 10 m.  
Power up with master every 10 m

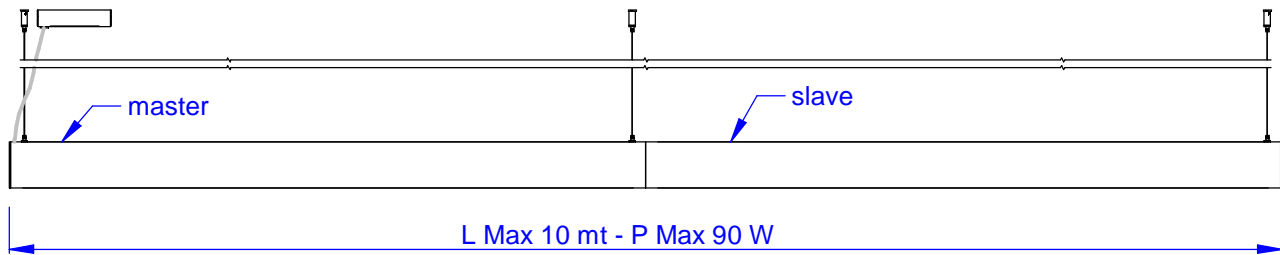

### EXAMPLE:

1) Microprismatic 30W n°3  
art. 83724 n°3

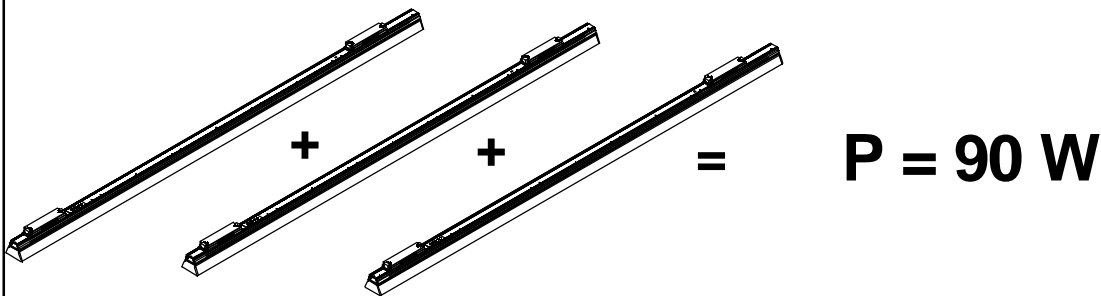

2) Microprismatic 30W n°2 + Cell\_WW n°1 + Projectors 12W n°1 + Optus\_Ex n°1

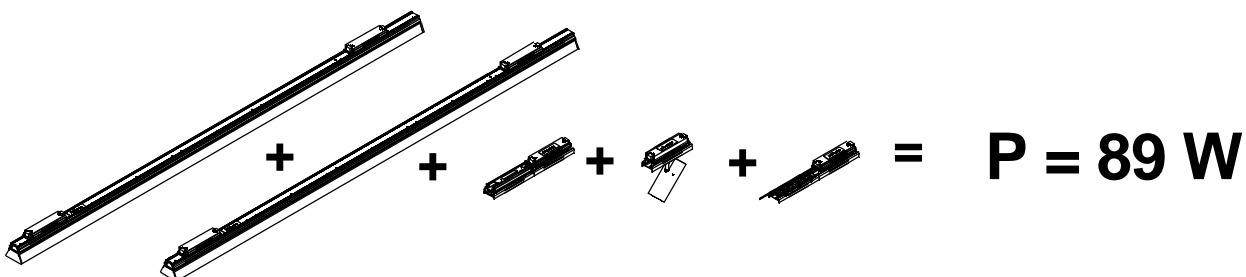



# MASTER L 2400 - 3000 MM

Rialimentare con un master ogni 10 m.  
Power up with master every 10 m

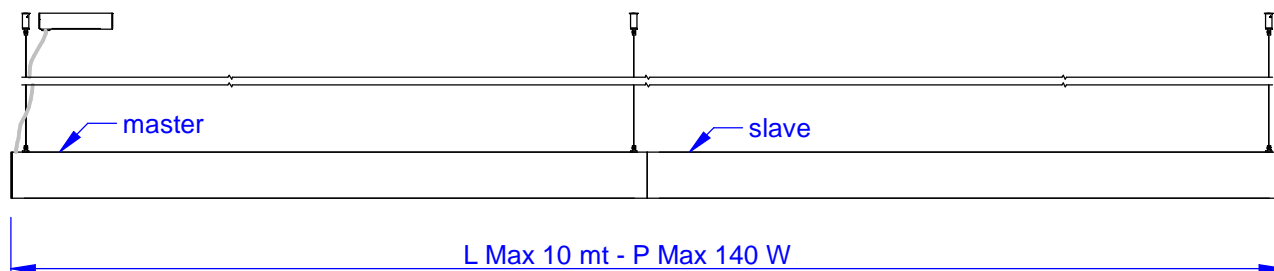

## EXAMPLE:

1) Microprismatic 30W n°3 + Cell n°1 + Cell\_WW n°1 + Projectors 7W n°1 + Projectors 12W n°1 + Optus\_EX n°1

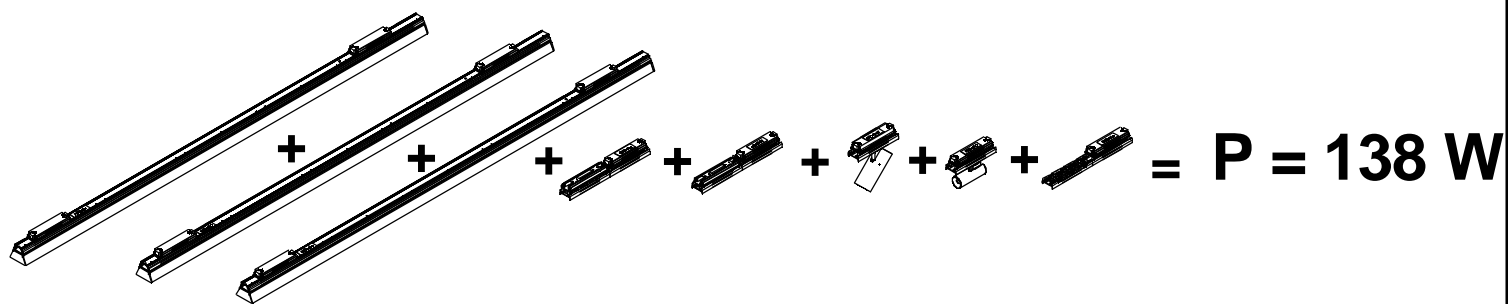

2) Projectors 12W n°11 + Projectors 7W n°1

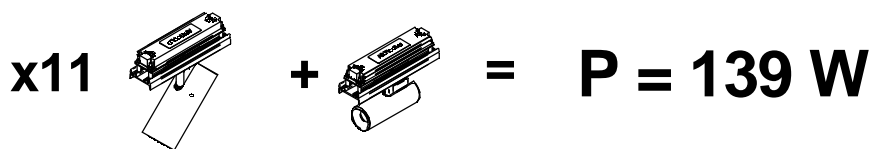

3) Optus\_EX n°28

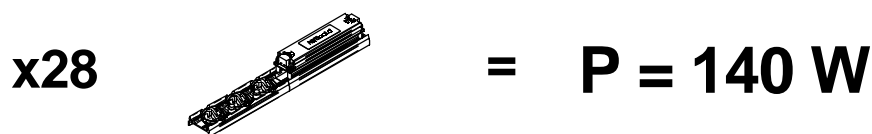

I	GB	F	D	E
<p><b>Procedura di cablaggio</b></p> <p>1 Chiudere l' interruttore generale <b>OFF</b></p> <p>2 Collegare i faretti all' alimentatore</p> <p>3 Collegare l' alimentatore alla rete</p> <p>4 Aprire l' interruttore generale <b>ON</b></p> <p>N.B</p> <p>Tutte le operazioni di manutenzione ed installazione vanno eseguite con l' interruttore generale in posizione <b>OFF</b></p> <p>Non collegare più faretti in parallelo all' uscita dello stesso alimentatore</p> <p>I faretti necessitano di corrente costante stabilizzata</p> <p>Per il N° di led collegabili all' alimentatore seguire le indicazioni sull'etichetta dello stesso</p> <p><b>IL FARETTO RISULTA GARANTITO SOLO CON ALIMENTATORI DISTRIBUITI DAI-I-LêD</b></p>	<p><b>Wiring procedure</b></p> <p>1 Switch off the main switch <b>OFF</b></p> <p>2 Connect the spotlights to the power supply unit.</p> <p>3 Connect the power supply unit to the network</p> <p>4 Switch on the main switch <b>ON</b></p> <p>N.B</p> <p>All the maintenance and installation procedures must be carried out with the main switch in position <b>OFF</b></p> <p>Do not connect too many parallel spotlights to the output of the same power supply unit</p> <p>Use stabilized constant current for the spotlights</p> <p>Follow the instructions on the label of the power supply unit for the number of spotlights that can be connected to it</p> <p><b>SPOTLIGHTS ARE GUARANTEED ONLY IF POWER SUPPLY UNITS DISTRIBUTED BY I-LêD ARE USED</b></p>	<p><b>Procédure de câblage</b></p> <p>1 Couper le disjoncteur <b>OFF</b></p> <p>2 Relier les spots au driver</p> <p>3 Relier le driver au réseau</p> <p>4 Connecter le disjoncteur <b>ON</b></p> <p>N.B.</p> <p>Toutes les opérations de maintenance et d'installation seront effectuées avec le disjoncteur sur la position <b>OFF</b></p> <p>Ne pas relier plusieurs spots en parallèle sur la sortie du même driver</p> <p>Les spots nécessitent d'un courant constant stabilisé</p> <p>Pour le N° de leds reliables au driver, suivre les indications reportées sur son étiquette</p> <p><b>LE SPOT EST GARANTI SEULEMENT AVEC LES DRIVERS DISTRIBUES PAR I-LêD</b></p>	<p><b>Anleitung zur Verkabelung</b></p> <p>1 Schalten Sie den Hauptschalter aus <b>OFF</b></p> <p>2 Schliessen Sie die Strahler an dem Stromversorgungsgeraet an</p> <p>3 Schliessen Sie das Stromversorgungsgeraet ans Netz an</p> <p>4 Schalten Sie den Hauptschalter ein <b>ON</b></p> <p>N.B</p> <p>Die Wartungs- und Instandhaltungsvorgänge müssen mit Hauptschalter in Position durchgeführt werden <b>OFF</b></p> <p>Schalten Sie weiterhin keinen Strahler mehr parallel am Ausgang desselben Stromversorgungsgeräts</p> <p>Die Strahler brauchen Konstantstrom</p> <p>Beachten Sie die Etikette des Stromversorgungsgeräts, um die Anzahl der am Stromversorgungsgerät anzuschliessenden LED zu erfahren.</p> <p><b>DIE GARANTIE IST GÜLTIG NUR FÜR STRAHLER, DIE MIT I-LêD STROMVERSORGUNGSGERÄTEN EINGESPEIST WERDEN.</b></p>	<p><b>Procedimiento de cableado</b></p> <p>1 Cerrar el interruptor general <b>OFF</b></p> <p>2 Conectar los focos al alimentador</p> <p>3 Conectar el alimentador a la red</p> <p>4 Abrir el interruptor general <b>ON</b></p> <p>N.B</p> <p>Todas las operaciones de mantenimiento e instalación se tendrán que llevar a cabo con el interruptor general en posición <b>OFF</b></p> <p>No conectar má focos en paralelo a la salida del mismo alimentador</p> <p>Los focos necesitan corriente constante estabilizada</p> <p>Sobre el N° de leds conectables al alimentador seguir las indicaciones indicadas en la etiqueta del mismo</p> <p><b>EL FOCO SÓLO ESTÁ GARANTIZADO CON ALIMENTADORES DISTRIBUIDOS POR I-LêD</b></p>

**MASTER/SLAVE**

24V DC

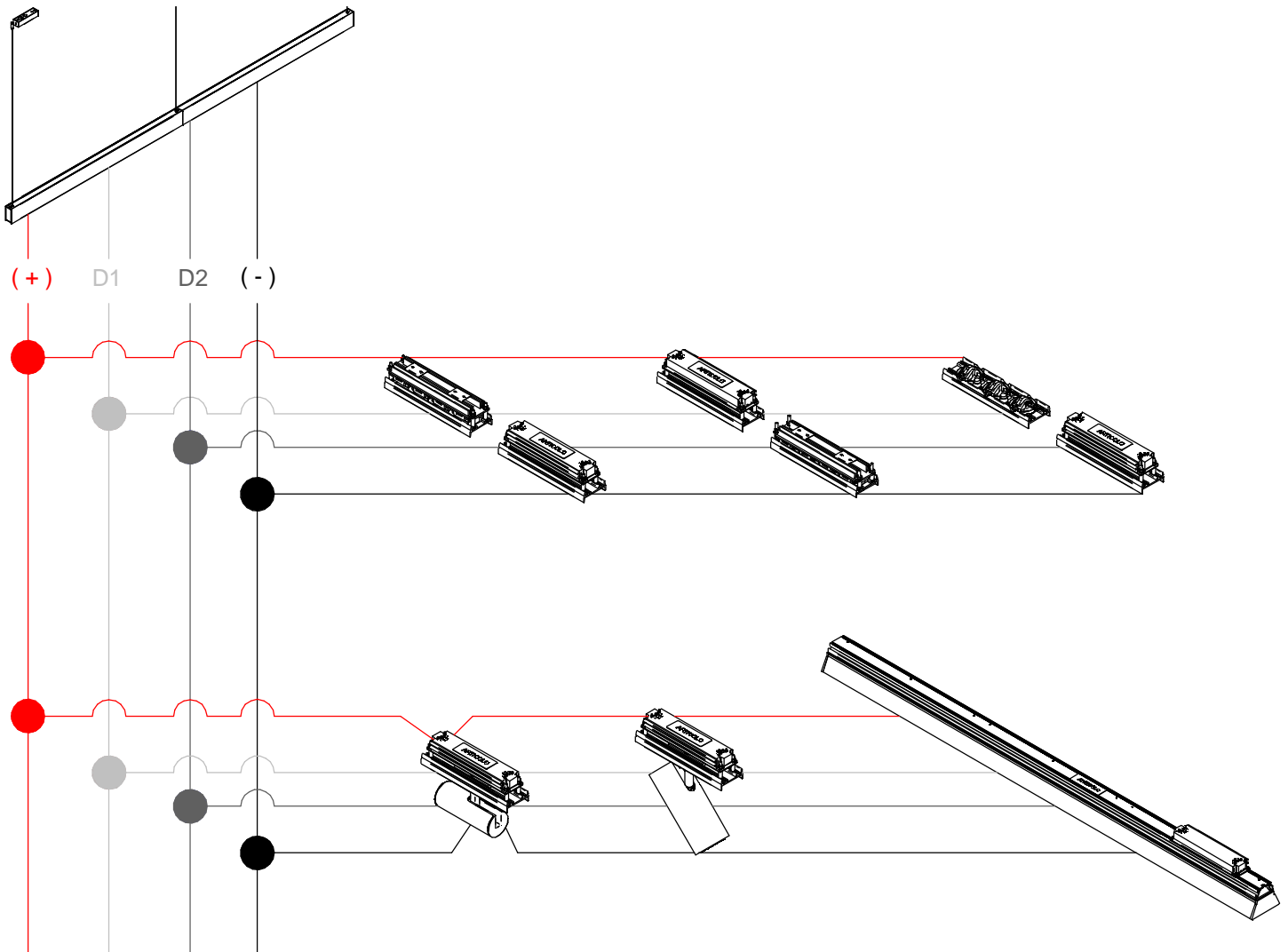

**(ITA)** - I prodotti devono essere installati tassativamente con alimentazioni, cablaggi e accessori originali del Gruppo Linea Light, o eventualmente approvati dall'azienda. L'utilizzo di accessori non originali, o non approvati, determina il decadimento di ogni garanzia sul prodotto. **(ENG)** - All power supply, wiring and accessories used for product installation shall be original Linea Light Group parts or approved by the company. The warranty will become void if non original or non approved parts are used. **(FRA)** - Les produits doivent impérativement être installés avec des alimentations, des câblages et des accessoires Linea Light Group, ou qui ont été approuvés par l'entreprise. L'utilisation d'accessoires non d'origine, ou non approuvés, entraîne la déchéance de toute garantie sur le produit. **(ESP)** - Los productos se han de instalar obligatoriamente con alimentaciones, cableados y accesorios originales de Linea Light Group o, de otra forma, deben ser aprobados por la empresa misma. El uso de accesorios no originales, o no aprobados, anula todas las garantías del producto. **(GER)** Die Produkte müssen obligatorisch mit Originalstromversorgung, Originalkabeln und Originalzubehör der Linea Light Group oder mit Teilen, die von der Linea Light Group ausdrücklich empfohlen sind, installiert werden. Die Verwendung von nicht originale oder nicht vom Hersteller empfohlenem Zubehör führt zu einem sofortigen Verfall vom Garantieanspruch für das Produkt.