

Serie : SKYLUM_Q - 620x620 - 935x935 - 1250x1250 mm

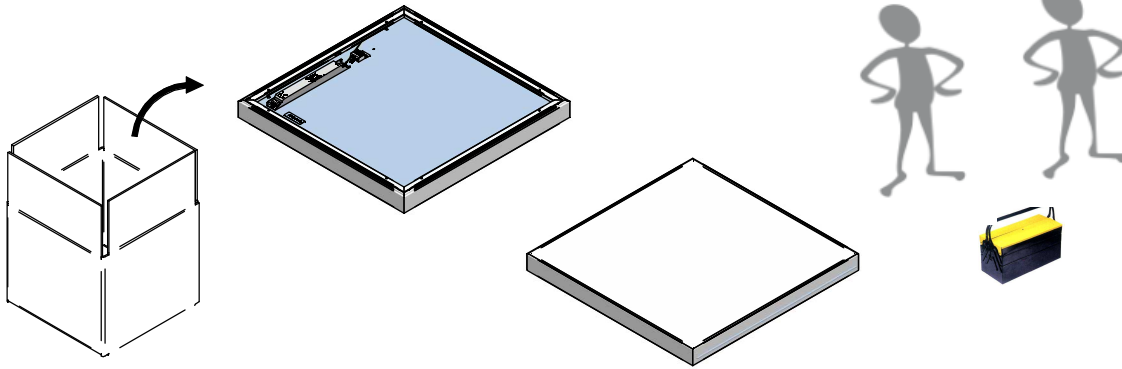

L'APPARECCHIO DEVE ESSERE INSTALLATO DA PERSONALE QUALIFICATO. L'AZIENDA DECLINA OGNI RESPONSABILITÀ QUALORA L'INSTALLAZIONE NON AVVENGA LASCIARE UNA COPIA DI QUESTE ISTRUZIONI AL RESPONSABILE DELLA MANUTENZIONE. CONSERVARE L'ETICHETTA DELL'IMBALLO ORIGINALE PER EVENTUALI RECLAMI FUTURI

THIS FIXTURE MUST BE INSTALLED BY A QUALIFICATED ELECTRICIAN. LINEA LIGHT IS NOT RESPONSABLE IF ITS FIXTURES ARE NOT INSTALLED ACCORDING TO LOCAL SAFETY STANDARDS. PLEASE LEAVE A COPY OF THESE INSTRUCTIONS TO THE PERSON RESPONSABLE FOR THE MAINTENANCE OF THE INSTALLATION. KEEP THE LABEL OF THE ORIGINAL PACKING FOR THE EVENTUAL FUTURE CLAIMS.

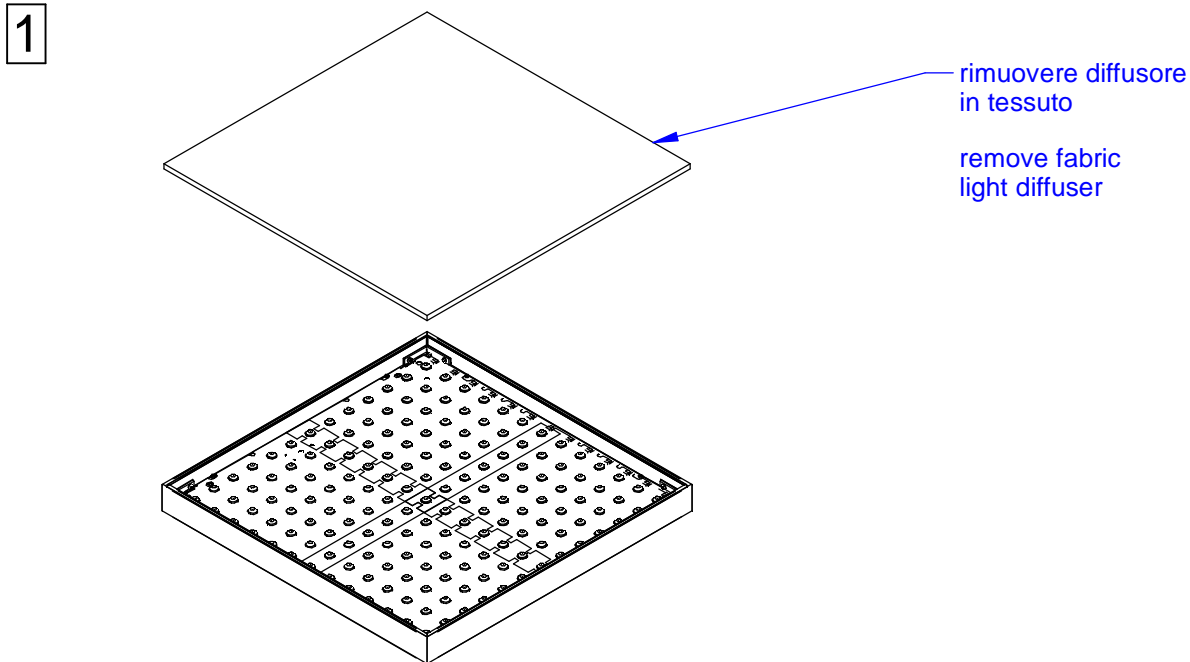

2 Posizione fori / Hole position

Posizione fori / Hole position

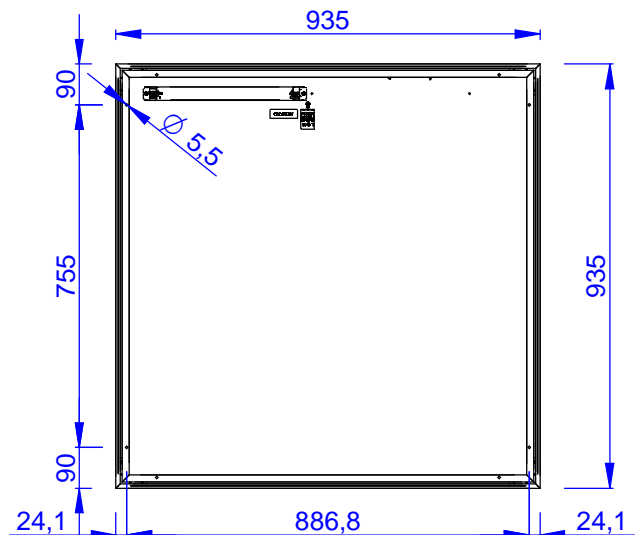
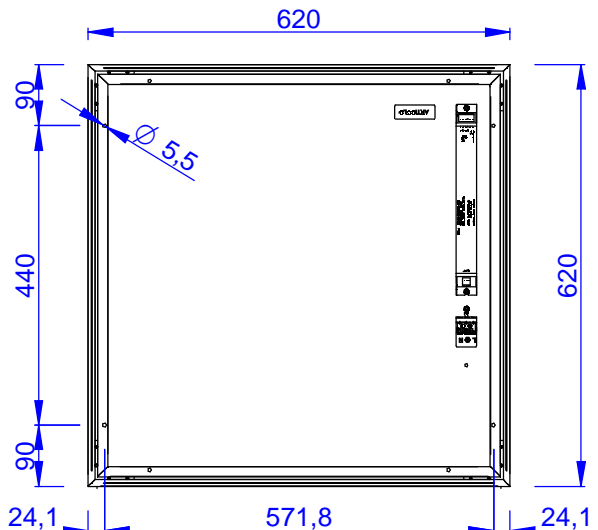

2

Posizione fori / Hole position

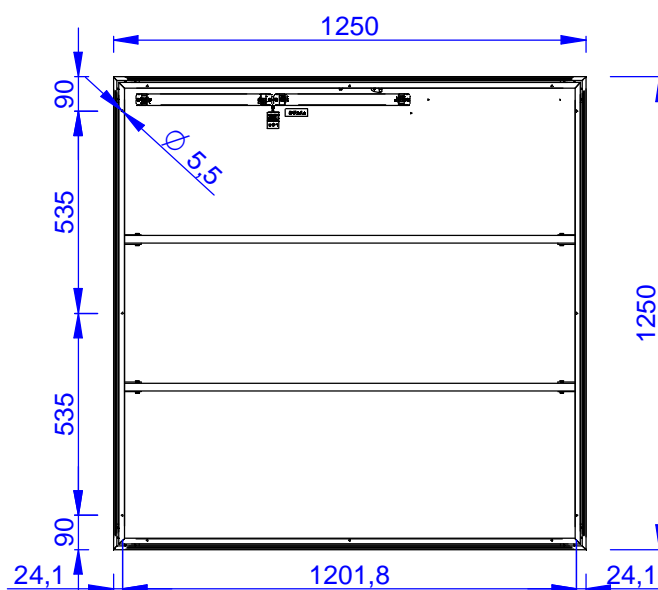

3

Segnare e forare soffitto / Mark and drill ceiling

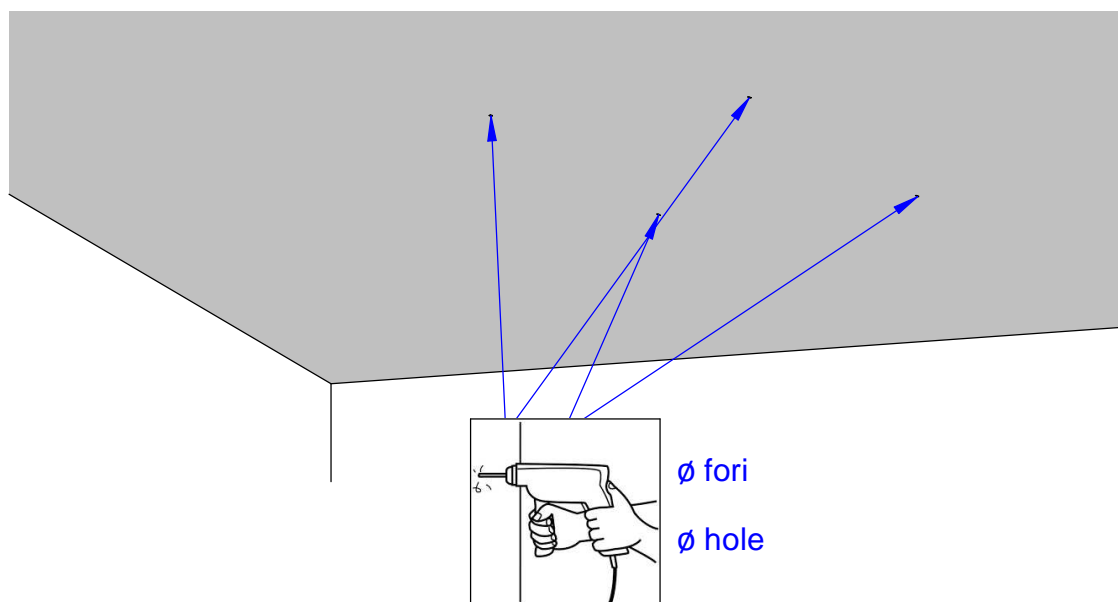
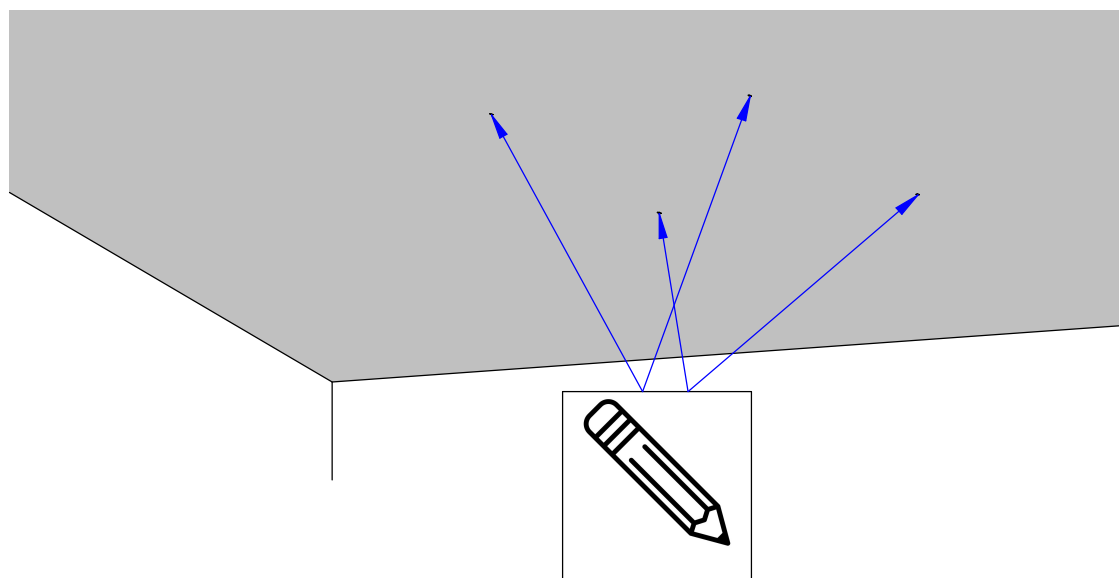

REGOLAZIONE LUMINOSA TRAMITE LA ROTAZIONE DIMMER - LIGHTING REGULATION FROM THE ROTATION OF DIMMER

4 Montaggio Tasselli / Wall plug assembly

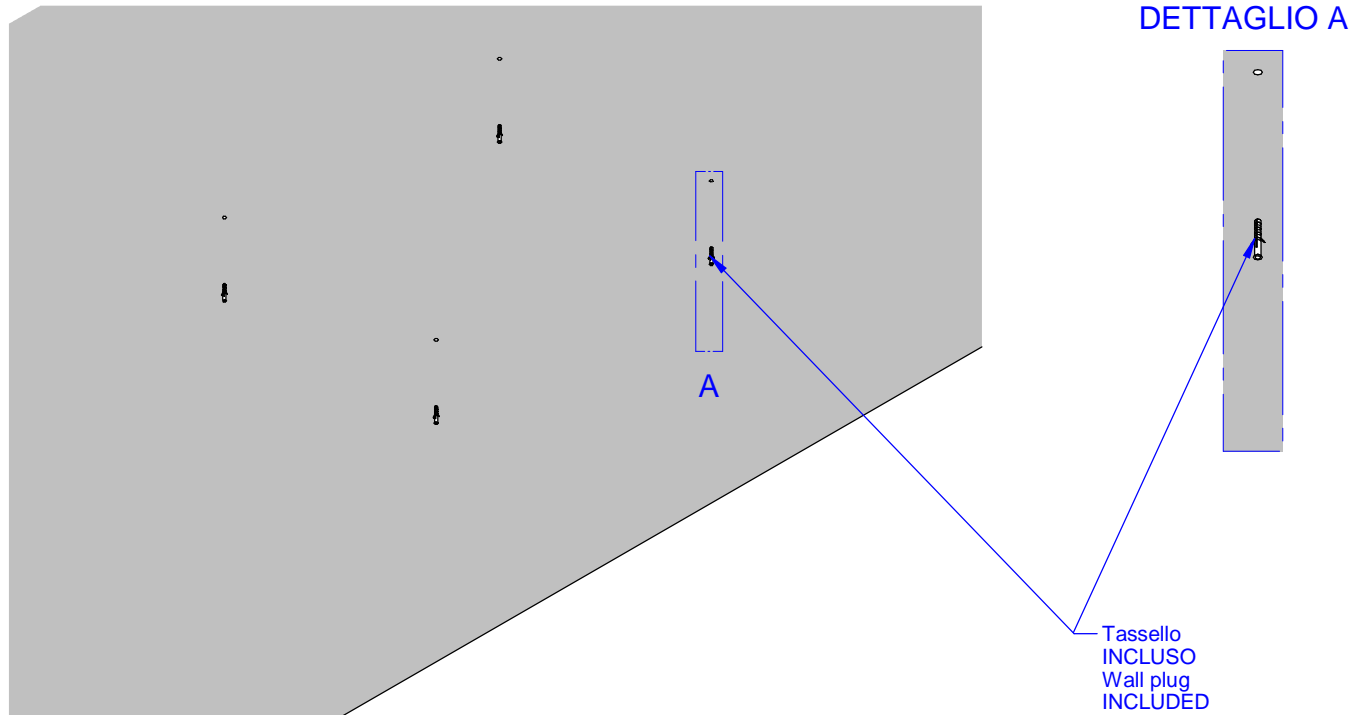

ATTENZIONE / ATTENTION:

620x620 fissare con 4 tasselli / 620x620 fix to 4 wall plug
 935x935 fissare con 4 tasselli / 935x935 fix to 4 wall plug
 1250x250 fissare con 6 tasselli / 1250x1250 fix to 6 wall plug

5 Cablaggio ON/OFF e DALI / Wiring ON/OFF and DALI

ON/OFF

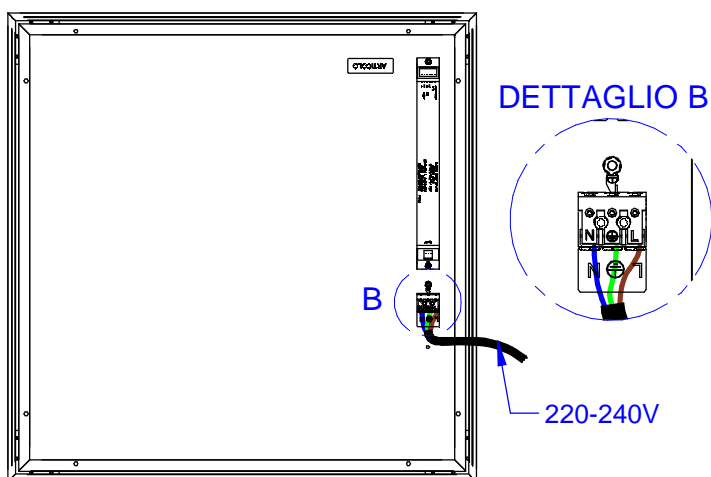

DALI

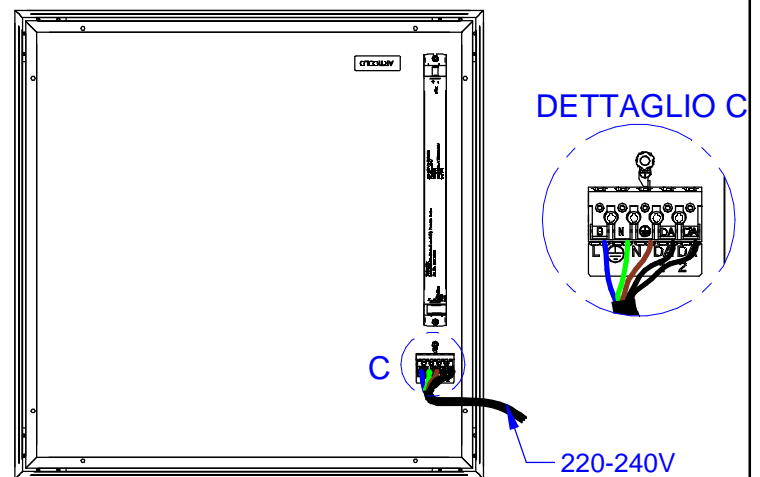

6 Cablaggio e fissaggio al soffitto / Wiring and fixing to the ceiling

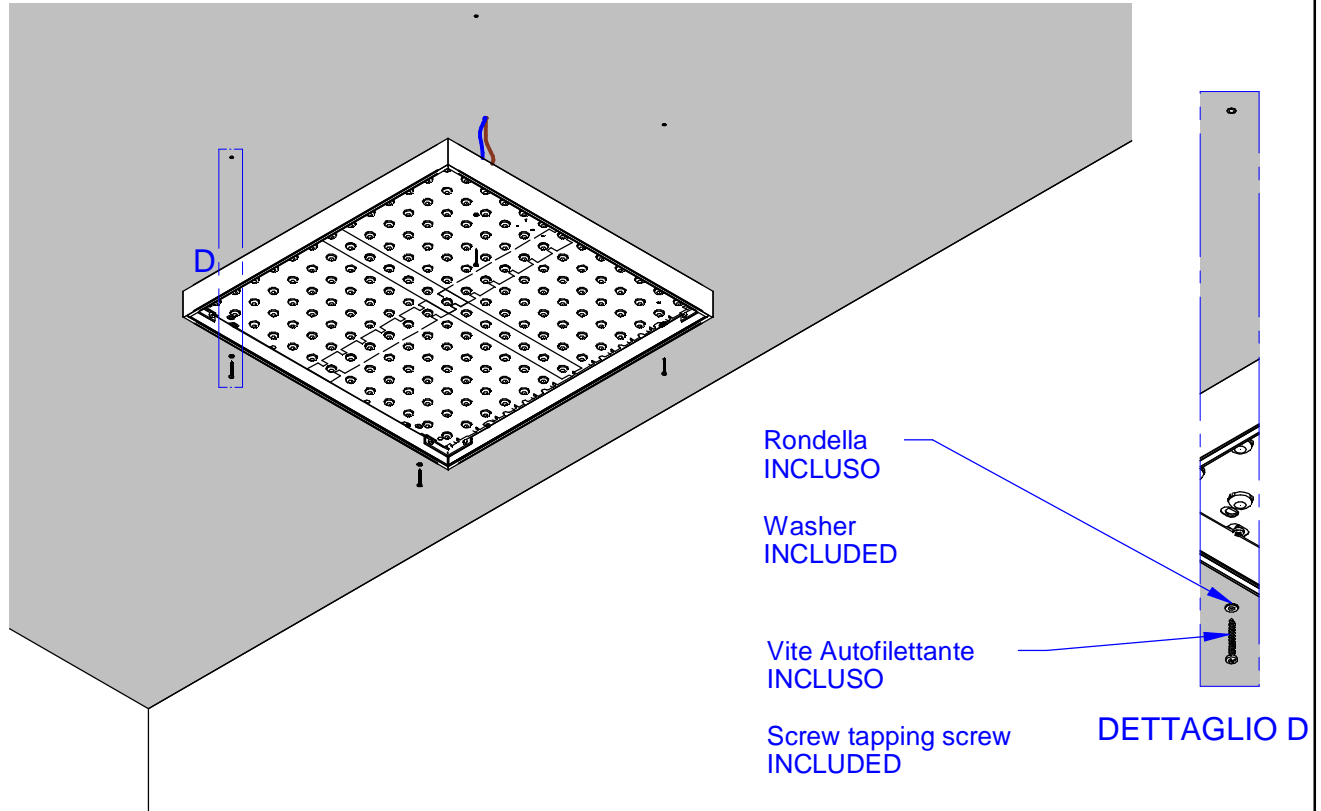

7 Montare Tappo foro passaggio vite / Fit the screw passage hole cap

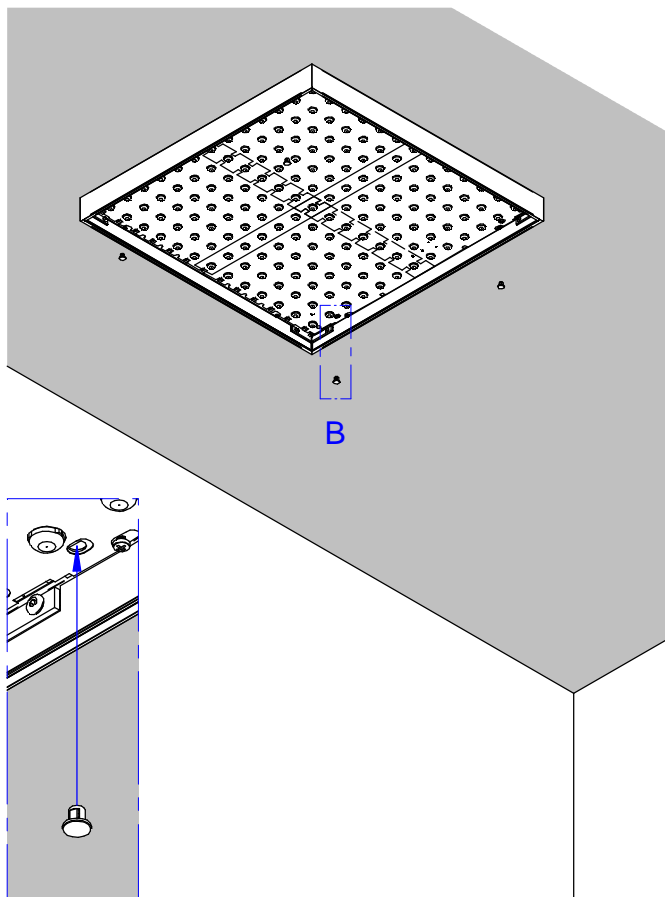

DETTAGLIO B

8 Montaggio diffusore in tessuto / Fabric light diffuser assembly

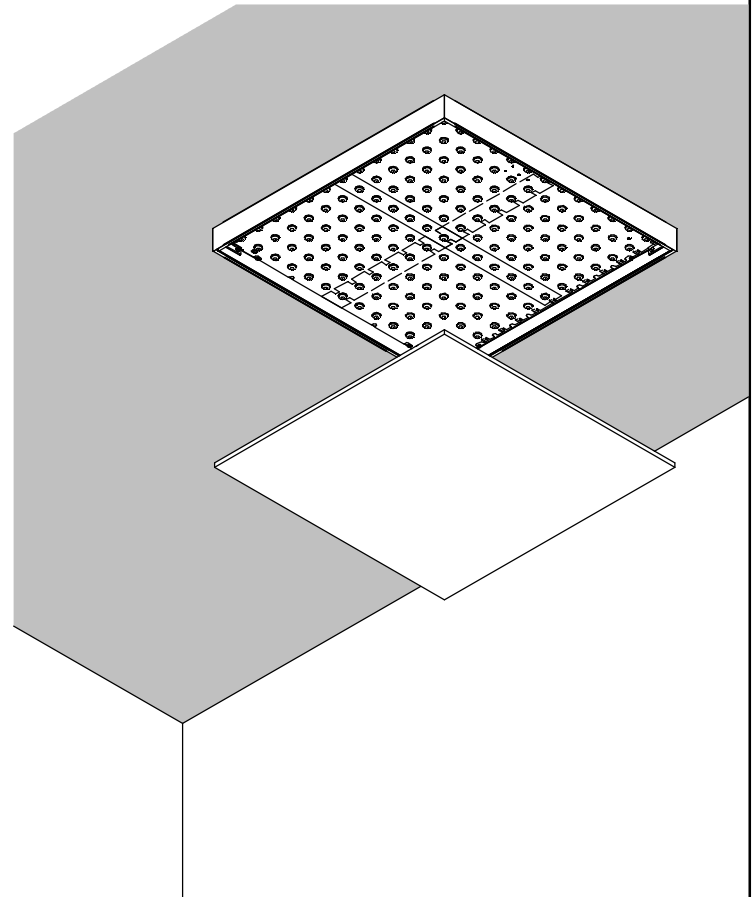

I	GB	F	D	E
<p>Procedura di cablaggio</p> <p>1 Chiudere l' interruttore generale OFF</p> <p>2 Collegare i faretti all' alimentatore</p> <p>3 Collegare l' alimentatore alla rete</p> <p>4 Aprire l' interruttore generale ON</p> <p>N.B.</p> <p>Tutte le operazioni di manutenzione ed installazione vanno eseguite con l' interruttore generale in posizione OFF</p> <p>Non collegare più faretti in parallelo all' uscita dello stesso alimentatore</p> <p>I faretti necessitano di corrente costante stabilizzata</p> <p>Per il N° di led collegabili all' alimentatore seguire le indicazioni sull'etichetta dello stesso</p> <p>IL FARETTO RISULTA GARANTITO SOLO CON ALIMENTATORI DISTRIBUITI DA I-LêD</p>	<p>Wiring procedure</p> <p>1 Switch off the main switch OFF</p> <p>2 Connect the spotlights to the power supply unit.</p> <p>3 Connect the power supply unit to the network</p> <p>4 Switch on the main switch ON</p> <p>N.B.</p> <p>All the maintenance and installation procedures must be carried out with the main switch in position OFF</p> <p>Do not connect too many parallel spotlights to the output of the same power supply unit</p> <p>Use stabilized constant current for the spotlights</p> <p>Follow the instructions on the label of the power supply unit for the number of spotlights that can be connected to it</p> <p>SPOTLIGHTS ARE GUARANTEED ONLY IF POWER SUPPLY UNITS DISTRIBUTED BY I-LêD ARE USED</p>	<p>Procédure de câblage</p> <p>1 Couper le disjoncteur OFF</p> <p>2 Relier les spots au driver</p> <p>3 Relier le driver au réseau</p> <p>4 Connecter le disjoncteur ON</p> <p>N.B.</p> <p>Toutes les opérations de maintenance et d'installation seront effectuées avec le disjoncteur sur la position OFF</p> <p>Ne pas relier plusieurs spots en parallèle sur la sortie du même driver</p> <p>Les spots nécessitent d'un courant constant stabilisé</p> <p>Pour le N° de leds reliables au driver, suivre les indications reportées sur son étiquette</p> <p>LE SPOT EST GARANTI SEULEMENT AVEC LES DRIVERS DISTRIBUES PAR I-LêD</p>	<p>Anleitung zur Verkabelung</p> <p>1 Schalten Sie den Hauptschalter aus OFF</p> <p>2 Schliessen Sie die Strahler an dem Stromversorgungsgerat an</p> <p>3 Schliessen Sie das Stromversorgungsgerat ans Netz an</p> <p>4 Schalten Sie den Hauptschalter ein ON</p> <p>N.B.</p> <p>Die Wartungs- und Instandhaltungsvorgänge müssen mit Hauptschalter in Position durchgeführt werden OFF</p> <p>Schalten Sie weiterhin keinen Strahler mehr parallel am Ausgang desselben Stromversorgungsgerats</p> <p>Die Strahler brauchen Konstantstrom</p> <p>Beachten Sie die Etikette des Stromversorgungsgerats, um die Anzahl der am Stromversorgungsgerat anzuschliessenden LED zu erfahren.</p> <p>DIE GARANTIE IST GÜLTIG NUR FÜR STRAHLER, DIE MIT I-LêD STROMVERSORUNGSGERÄTEN EINGESPEIST WERDEN.</p>	<p>Procedimiento de cableado</p> <p>1 Cerrar el interruptor general OFF</p> <p>2 Conectar los focos al alimentador</p> <p>3 Conectar el alimentador a la red</p> <p>4 Abrir el interruptor general ON</p> <p>N.B.</p> <p>Todas las operaciones de mantenimiento e instalación se tendrán que llevar a cabo con el interruptor general en posición OFF</p> <p>No conectar má focos en paralelo a la salida del mismo alimentador</p> <p>Los focos necesitan corriente constante estabilizada</p> <p>Sobre el N° de leds conectables al alimentador seguir las indicaciones indicadas en la etiqueta del mismo</p> <p>EL FOCO SÓLO ESTÁ GARANTIZADO CON ALIMENTADORES DISTRIBUIDOS POR I-LêD</p>

ON/OFF

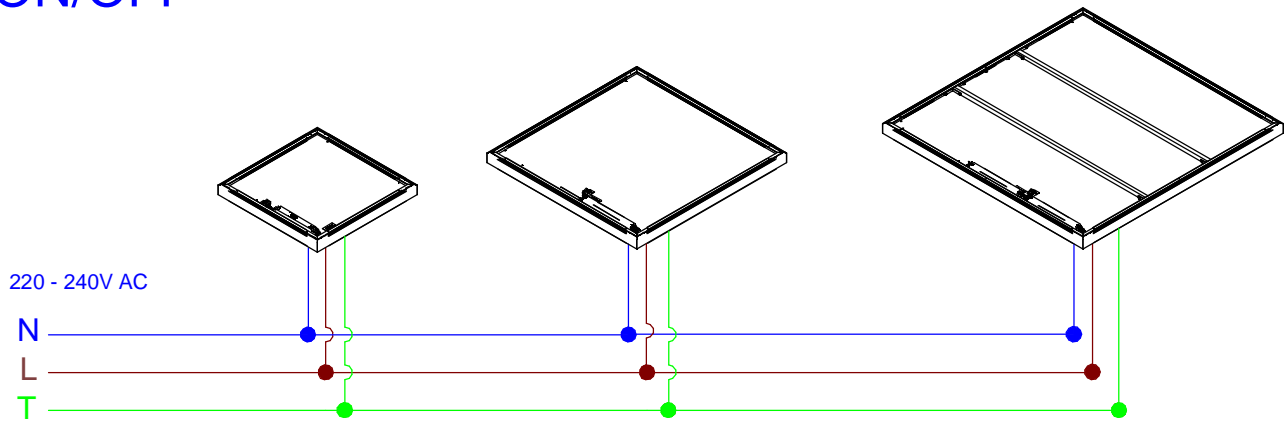

DALI

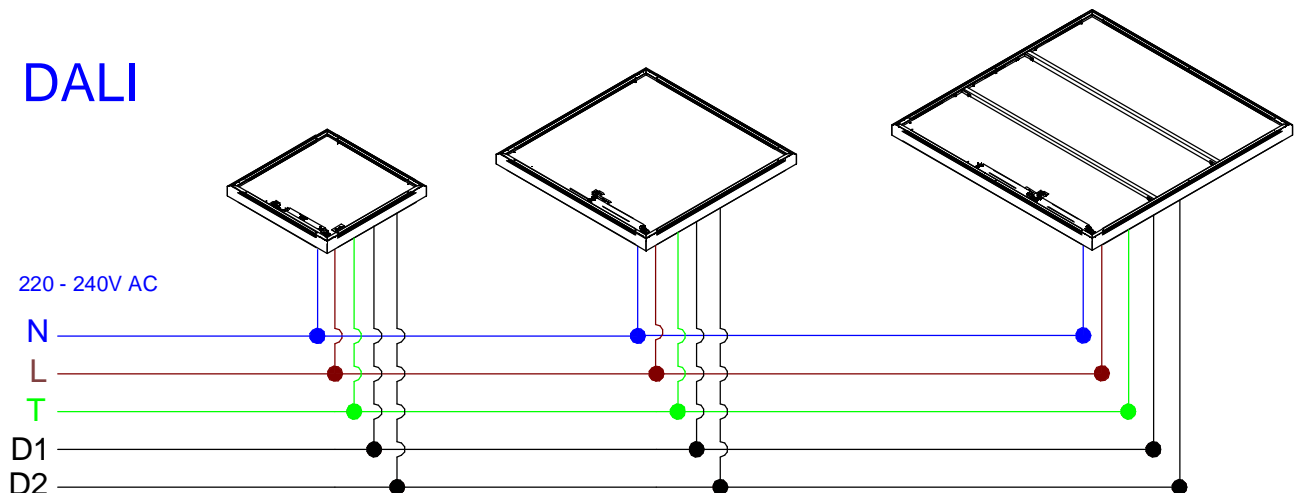

(ITA) - I prodotti devono essere installati tassativamente con alimentazioni, cablaggi e accessori originali del Gruppo Linea Light, o eventualmente approvati dall'azienda. L'utilizzo di accessori non originali, o non approvati, determina il decadimento di ogni garanzia sul prodotto. **(ENG)** - All power supply, wiring and accessories used for product installation shall be original Linea Light Group parts or approved by the company. The warranty will become void if non original or non approved parts are used. **(FRA)** - Les produits doivent impérativement être installés avec des alimentations, des câblages et des accessoires Linea Light Group, ou qui ont été approuvés par l'entreprise. L'utilisation d'accessoires non d'origine, ou non approuvés, entraîne la déchéance de toute garantie sur le produit. **(ESP)** - Los productos se han de instalar obligatoriamente con alimentaciones, cableados y accesorios originales de Linea Light Group o, de otra forma, deben ser aprobados por la empresa misma. El uso de accesorios no originales, o no aprobados, anula todas las garantías del producto. **(GER)** Die Produkte müssen obligatorisch mit Originalstromversorgung, Originalkabeln und Originalzubehör der Linea Light Group oder mit Teilen, die von der Linea Light Group ausdrücklich empfohlen sind, installiert werden. Die Verwendung von nicht originale oder nicht vom Hersteller empfohlenem Zubehör führt zu einem sofortigen Verfall vom Garantieanspruch für das Produkt.