

**ISTRUZIONI DI MONTAGGIO - MOUNTING INSTRUCTIONS**

**I**  
L'APPARECCHIO DEVE ESSERE INSTALLATO DA PERSONALE QUALIFICATO.  
L'AZIENDA DECLINA OGNI RESPONSABILITÀ QUALORA L'INSTALLAZIONE NON AVVENGA SECONDO LE NORME VIGENTI.  
LASCIARE UNA COPIA DI QUESTE ISTRUZIONI AL RESPONSABILE DELLA MANUTENZIONE.  
CONSERVARE L'ETICHETTA DELL'IMBALLLO ORIGINALE PER EVENTUALI RECLAMI FUTURI

**GB**  
THIS FIXTURE MUST BE INSTALLED BY A QUALIFIED ELECTRICIAN. LINEA LIGHT IS NOT RESPONSIBLE IF ITS FIXTURES ARE NOT INSTALLED ACCORDING TO LOCAL SAFETY STANDARDS.  
PLEASE LEAVE A COPY OF THESE INSTRUCTIONS TO THE PERSON RESPONSIBLE FOR THE MAINTENANCE OF THE INSTALLATION.  
KEEP THE LABEL OF THE ORIGINAL PACKING FOR THE EVENTUAL

**F**  
L'APPAREIL DOIT ETRE INSTALLE PAR ELECTRICIENS QUALIFIES. LINEA LIGHT NE PEUT PAS ETRE RESPONSABLE POUR TOUTES INSTALLATIONS QUI NE RESPECTENT PAS LES NORMES DE SECURITE EN VIGUER.  
LAISSER UNE COPIE DE CES INSTRUCTIONS AU RESPONSABLE DE L'ENTRETIEN DU SYSTEME.  
GARDER L'ETIQUETTE DE L'EMBALLAGE ORIGINAL POUR EVENTUELLES RECLAMATIONS FUTURES.

**D**  
DAS GERÄT MUSS VON ELEKTROINSTALLATEUREN MONTIERT WERDEN.  
LINEA LIGHT IST NICHT VERANTWORTLICH WENN DIE MONTAGE NICHT GEMÄß DER SICHERHEITSVORSCHRIFTEN STÄTTFINDET.  
DIESES HINWEISBLATT MUß VOM INSTANDHALTUNGSLEITER AUFBEWAHRT WERDEN.  
BEI REKLAMATIONEN BITTE DEN ARTIKELAUFLER AUS DER LEUCHTENVERPACKUNG BEIFÜGEN.

**E**  
EL APARATO DEBE SER INSTALADO POR ELECTRICISTAS CUALIFICADOS. LINEA LIGHT NO SE RESPONSABILIZARA DE TODAS LAS INSTALACIONES QUE NO RESPETEN LAS NORMAS DASEGURIDAD EN VIGOR.  
ENTREGAR UNA COPIA DE ESTAS INSTRUCCIONES AL RESPONSABLE DE LA INSTALACION.  
CONSERVAR LA ETIQUETA DEL EMBALAJE ORIGINAL PARA POSIBLES RECLAMACIONES.

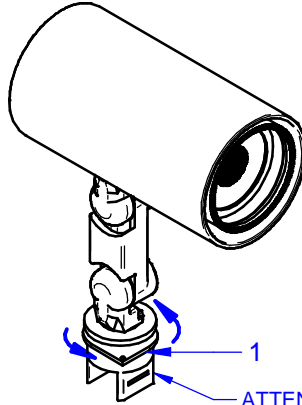
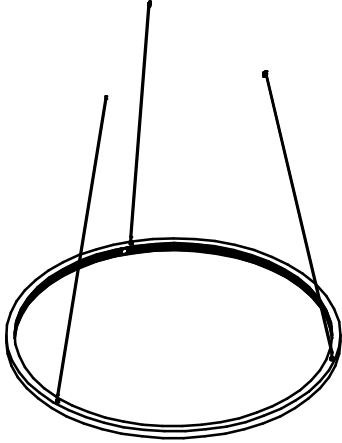

**ATTENZIONE:** Il pezzo indicato con il numero 1 può ruotare per andare ad incastrarsi nel tour (vedi sezione), per ruotare aiutarsi con un oggetto appuntito utilizzando i rispettivi fori.

**ATTENTION:** The piece indicated with the number 1 can rotate to fit together in the tour (see the section), to rotate use a pointed object, using the respective holes.

ATTENZIONE IL LATO INCISO VA SEMPRE VERSO IL BASSO  
ATTENTION THE ENGRAVED SIDE ALWAYS GOES DOWN

**1** Polarità cavo di alimentazione faretto | Polarity of the spotlight power cable

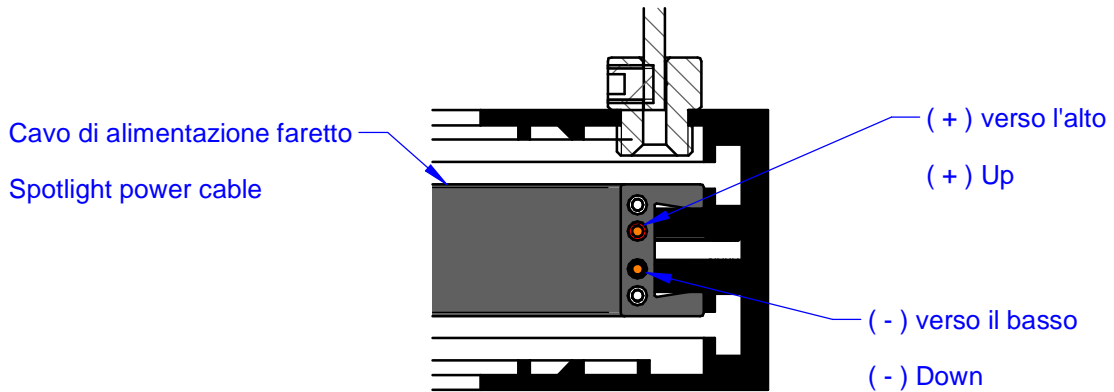

**2**

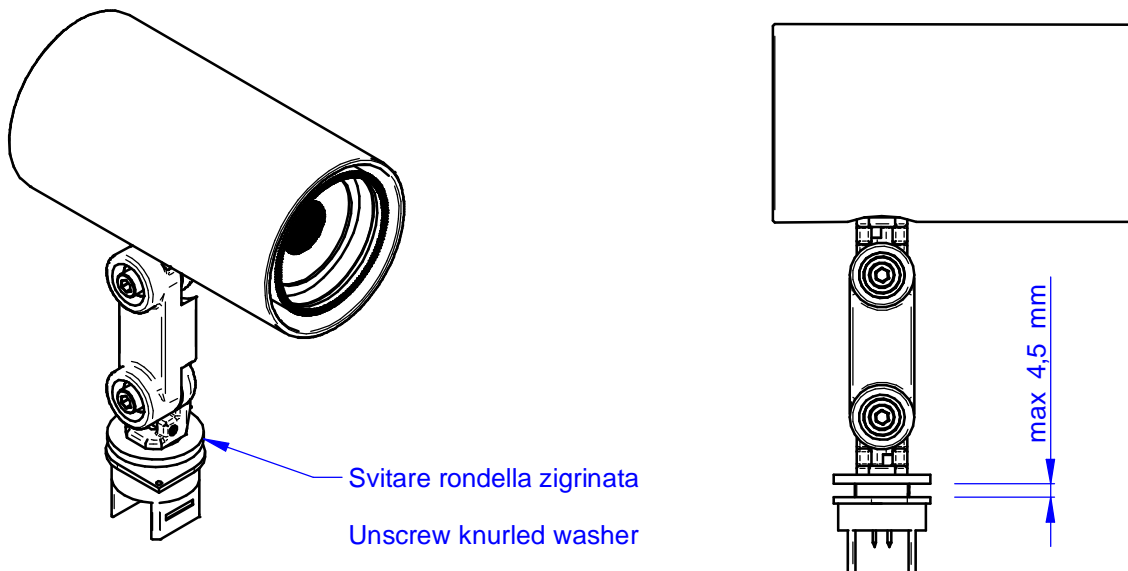

**ISTRUZIONI DI MONTAGGIO - MOUNTING INSTRUCTIONS**

3

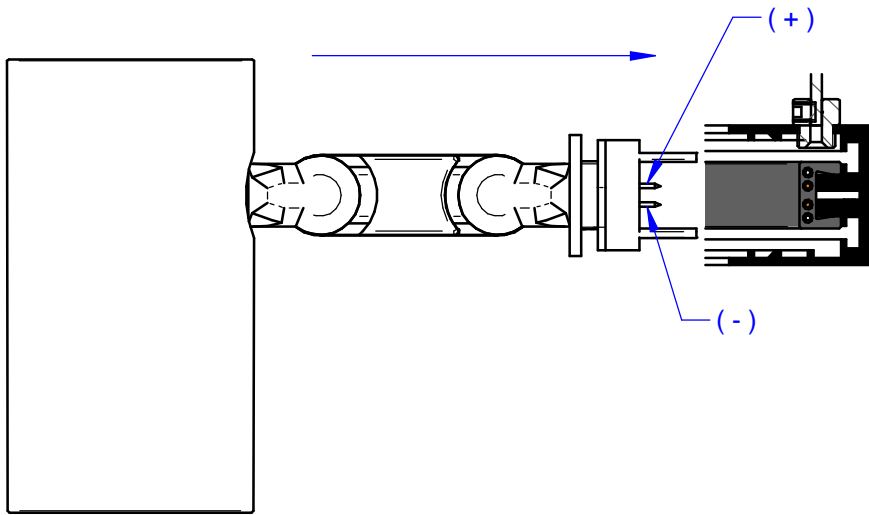
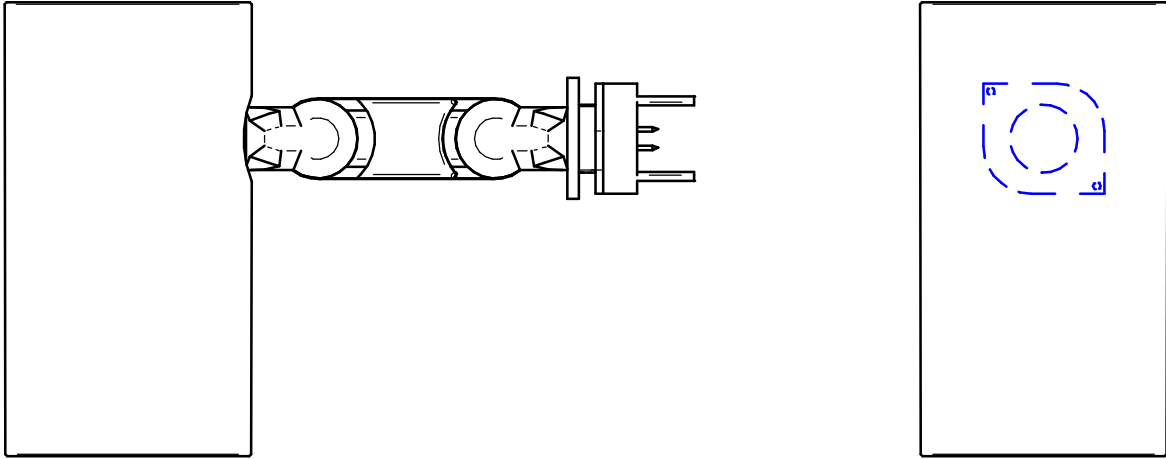

4

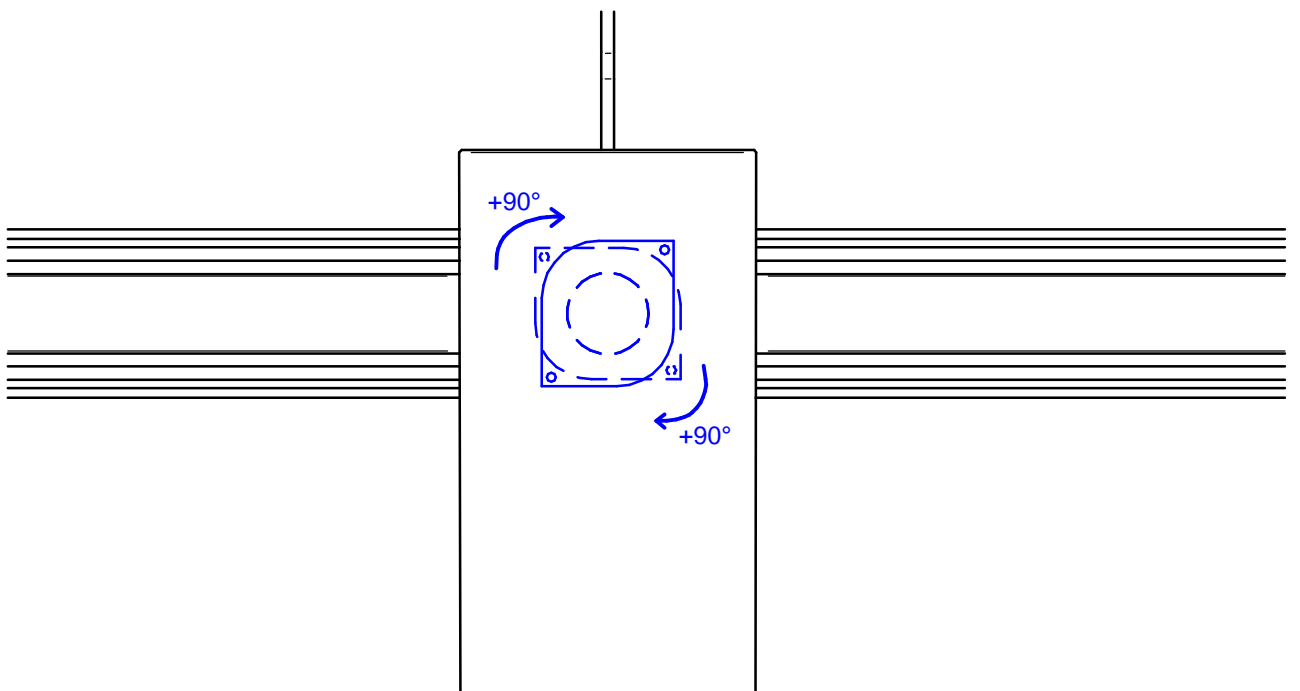

5

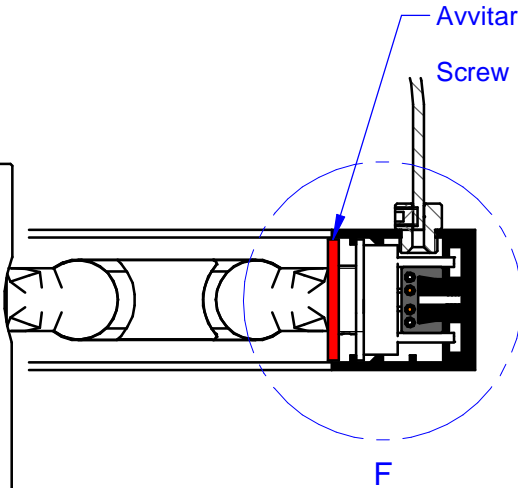
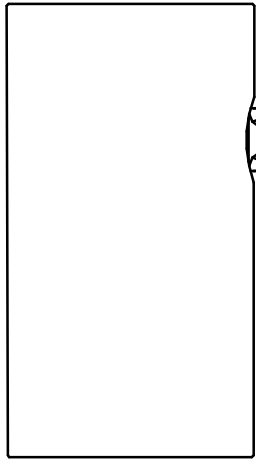

F

Prima/ Before

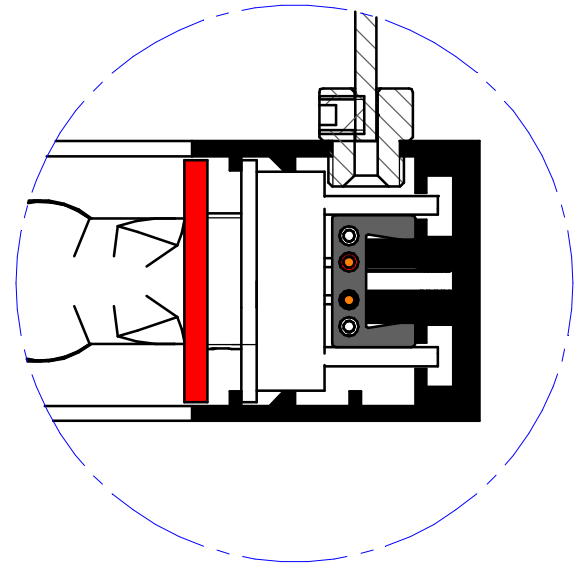

DETTAGLIO F

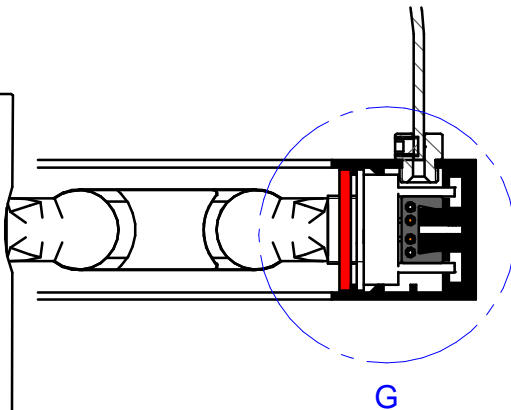
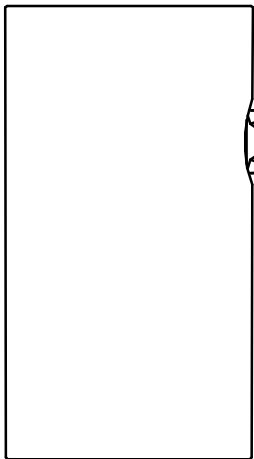

G

Dopo/ After

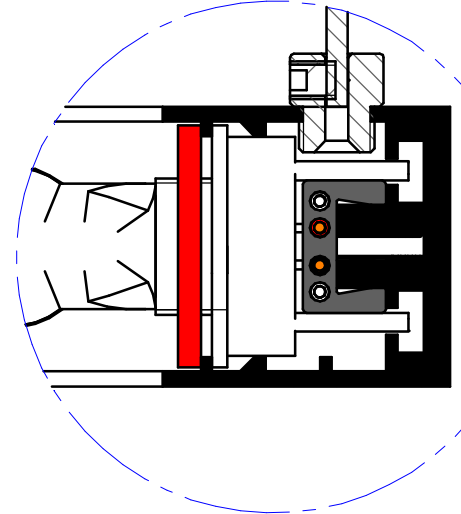

DETTAGLIO G

6

RIFERIMENTO LED-FGI811  
REFERENCE LED-FGI811

