

Serie : Optus_EX Mini

Do not stare at the operating light source



I
L'APPARECCHIO DEVE ESSERE INSTALLATO DA PERSONALE QUALIFICATO.
L'AZIENDA DECLINA OGNI RESPONSABILITÀ QUALORA L'INSTALLAZIONE NON AVVENGA SECONDO LE NORME VIGENTI. LASCIARE UNA COPIA DI QUESTE ISTRUZIONI AL RESPONSABILE DELLA MANUTENZIONE. CONSERVARE L'ETICHETTA DELL'IMBALLO ORIGINALE PER EVENTUALI RECLAMI FUTURI

GB
THIS FIXTURE MUST BE INSTALLED BY A QUALIFIED ELECTRICIAN. LINEA LIGHT IS NOT RESPONSIBLE FOR ITS FIXTURES ARE NOT INSTALLED ACCORDING TO LOCAL SAFETY STANDARDS. PLEASE LEAVE A COPY OF THESE INSTRUCTIONS TO THE PERSON RESPONSABLE FOR THE MAINTENANCE OF THE INSTALLATION. KEEP THE LABEL OF THE ORIGINAL PACKING FOR THE EVENTUAL FUTURE CLAIMS

F
L'APPAREIL DOIT ETRE INSTALLE PAR ELECTRICIENS QUALIFIES. LINEA LIGHT NE PEUT PAS ETRE RESPONSABLE POUR TOUTES INSTALLATIONS QUI NE RESPECTENT PAS LES NORMES DE SECURITE EN VIGUER. LAISSER UNE COPIE DE CES INSTRUCTIONS AU RESPONSABLE DE L'ENTRETIEN DU SYSTEME. GARDER L'ETIQUETTE DE L'EMBALLAGE ORIGINAL POUR EVENTUELLES RECLAMATIONS FUTURES.

D
DAS GERÄT MUSS VON ELEKTROINSTALLATEUREN MONTIERT WERDEN. LINEA LIGHT IST NICHT VERANTWORTLICH WENN DIE MONTAGE NICHT GEMÄß DER SICHERHEITSVORSCHRIFTEN STATTFINDET. DIESES HINWEISBLATT MUß VOM INSTANDHALTUNGSLEITER AUFBEWAHRT WERDEN. BEI REKLAMATIONEN BITTE DEN ARTIKELAUFKLEBER AUS DER LEUCHTENVERPACKUNG BEIFÜGEN.

E
EL APARATO DEBE SER INSTALADO POR ELECTRICISTAS CUALIFICADOS. LINEA LIGHT NO SE RESPONSABILIZARA DE TODAS L. INSTALACIONES QUE NO RESPETEN LAS NORMAS D SEGURIDAD EN VIGOR. ENTREGAR UNA COPIA DE ESTAS INSTRUCCIONES AL RESPONSABLE DE LA INSTALACION. CONSERVAR LA ETIQUETA DEL EMBALAJE ORIGINAL PARA POSIBLES RECLAMACIONES.

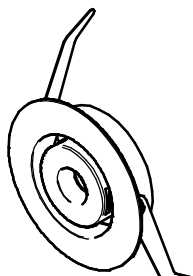
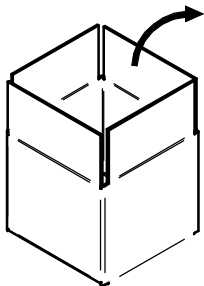

82737
82738

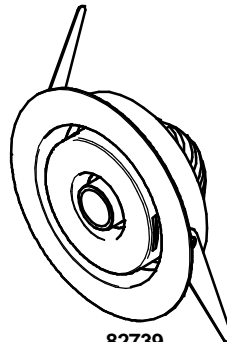

82739
82740

Etichetta energetica scaricabile dal sito www.linealight.com
Energy label downloaded from the website www.linealight.com

| CODICE ARTICOLO ARTICLE CODE | Ø FORO Ø HOLE |
|---------------------------------|------------------|
| 82737 / 82738 | 46 |
| 82739 / 82740 | 66 |

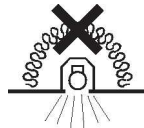
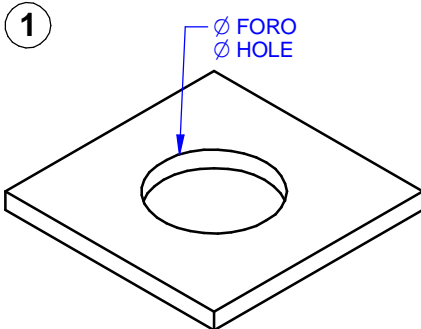

N.B.

(ITA) - Non coprire l'articolo con materiale isolante.
(ENG) - Do not cover the product with insulating material.
(FRA) - Ne pas couvrir le produit avec un matériau isolant.
(ESP) - No cubra el producto con material aislante.
(GER) - Das Produkt nicht decken mit Isoliermaterial.

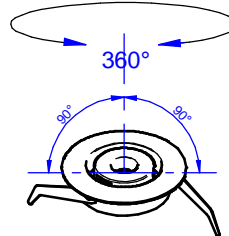
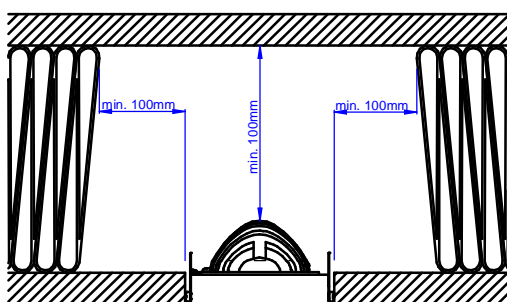

45°



90°



2

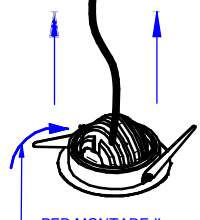
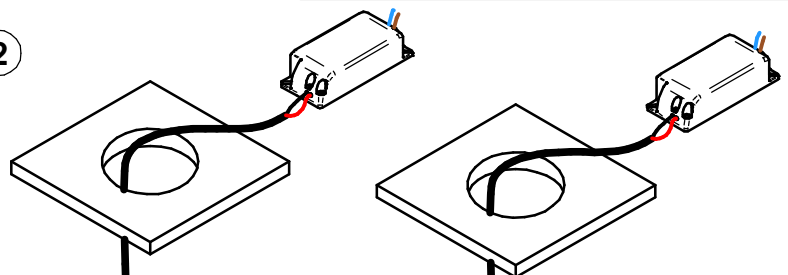

PER MONTARE IL FARETTO RUOTARE VERSO DESTRA PREMENDO LE MOLLE VERSO IL CORPO
TO FIT THE SPOTLIGHT ROTATE TO THE RIGHT PRESSING THE SPRINGS TOWARDS THE BODY

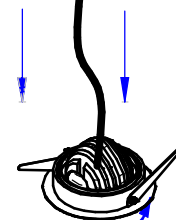

PER ESTRARRE IL FARETTO RUOTARE VERSO SINISTRA E TIRARE VERSO IL BASSO
TO EXTRACT THE SPOTLIGHT ROTATE TO THE LEFT AND PULL DOWN

Serie : Optus_EX Mini

REGOLAZIONE OTTICA FOCUS (85) - OPTICAL ADJUSTMENT FOCUS (85)

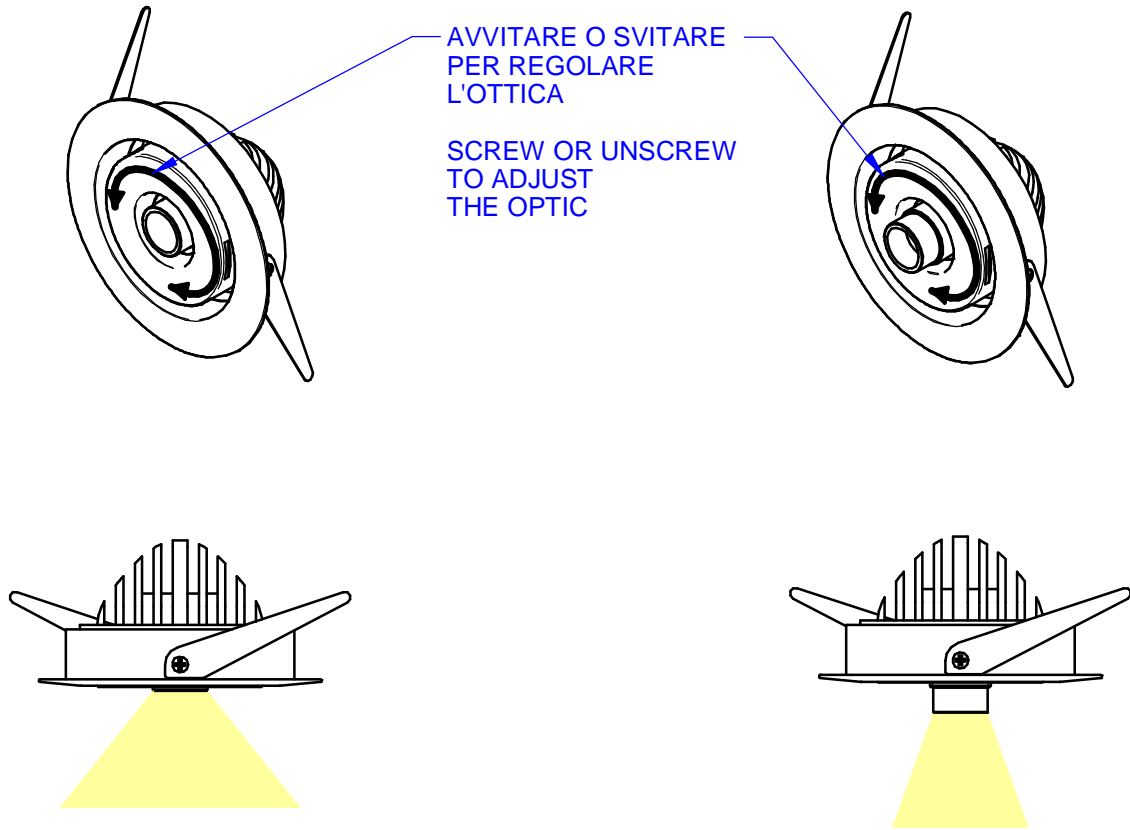

AVVITARE O SVITARE PER REGOLARE L'OTTICA

SCREW OR UNSCREW TO ADJUST THE OPTIC

(ITA) - I prodotti devono essere installati tassativamente con alimentazioni, cablaggi e accessori originali del Gruppo Linea Light, o eventualmente approvati dall'azienda. L'utilizzo di accessori non originali, o non approvati, determina il decadimento di ogni garanzia sul prodotto. **(ENG)** - All power supply, wiring and accessories used for product installation shall be original Linea Light Group parts or approved by the company. The warranty will become void if non original or non approved parts are used. **(FRA)** - Les produits doivent impérativement être installés avec des alimentations, des câblages et des accessoires Linea Light Group, ou qui ont été approuvés par l'entreprise. L'utilisation d'accessoires non d'origine, ou non approuvés, entraîne la déchéance de toute garantie sur le produit. **(ESP)** - Los productos se han de instalar obligatoriamente con alimentaciones, cableados y accesorios originales de Linea Light Group o, de otra forma, deben ser aprobados por la empresa misma. El uso de accesorios no originales, o no aprobados, anula todas las garantías del producto. **(GER)** Die Produkte müssen obligatorisch mit Originalstromversorgung, Originalkabeln und Originalzubehör der Linea Light Group oder mit Teilen, die von der Linea Light Group ausdrücklich empfohlen sind, installiert werden. Die Verwendung von nicht originalelem oder nicht vom Hersteller empfohlenem Zubehör führt zu einem sofortigen Verfall vom Garantieanspruch für das Produkt.

| I | GB | F | D | E |
|---|--|---|--|---|
| <p>Procedura di cablaggio</p> <ol style="list-style-type: none"> 1 Chiudere l'interruttore generale OFF 2 Collegare i faretti all'alimentatore 3 Collegare l'alimentatore alla rete 4 Aprire l'interruttore generale ON <p>N.B.</p> <p>Tutte le operazioni di manutenzione ed installazione vanno eseguite con l'interruttore generale in posizione OFF</p> <p>Non collegare più faretti in parallelo all'uscita dello stesso alimentatore</p> <p>I faretti necessitano di corrente costante stabilizzata</p> <p>Per il N° di led collegabili all'alimentatore seguire le indicazioni sull'etichetta dello stesso</p> <p>IL FARETTO RISULTA GARANTITO SOLO CON ALIMENTATORI DISTRIBUITI DA I-LèD</p> | <p>Wiring procedure</p> <ol style="list-style-type: none"> 1 Switch off the main switch OFF 2 Connect the spotlights to the power supply unit. 3 Connect the power supply unit to the network 4 Switch on the main switch ON <p>N.B.</p> <p>All the maintenance and installation procedures must be carried out with the main switch in position OFF</p> <p>Do not connect too many parallel spotlights to the output of the same power supply unit</p> <p>Use stabilized constant current for the spotlights</p> <p>Follow the instructions on the label of the power supply unit for the number of spotlights that can be connected to it</p> <p>SPOTLIGHTS ARE GUARANTEED ONLY IF POWER SUPPLY UNITS DISTRIBUTED BY I-LèD ARE USED</p> | <p>Procédure de câblage</p> <ol style="list-style-type: none"> 1 Couper le disjoncteur OFF 2 Relier les spots au driver 3 Relier le drier au réseau 4 Connecter le disjoncteur ON <p>N.B.</p> <p>Toutes les opérations de maintenance et d'installation seront effectuées avec le disjoncteur sur la position OFF</p> <p>Ne pas relier plusieurs spots en parallèle sur la sortie du même driver</p> <p>Les spots nécessitent d'un courant constant stabilisé</p> <p>Pour le N° de leds reliables au driver, suivre les indications reportées sur son étiquette</p> <p>LE SPOT EST GARANTI SEULEMENT AVEC LES DRIVERS DISTRIBUES PAR I-LèD</p> | <p>Anleitung zur Verkabelung</p> <ol style="list-style-type: none"> 1 Schalten Sie den Hauptschalter aus OFF 2 Schließen Sie die Strahler an dem Stromversorgungsgerät an 3 Schließen Sie das Stromversorgungsgerät ans Netz an 4 Schalten Sie den Hauptschalter ein ON <p>N.B.</p> <p>Die Wartungs- und Instandhaltungsvorgänge müssen mit Hauptschalter in Position durchgeführt werden OFF</p> <p>Schalten Sie weiterhin keinen Strahler mehr parallel am Ausgang desselben Stromversorgungsgeräts</p> <p>Die Strahler brauchen Konstantstrom</p> <p>Beachten Sie die Etikette des Stromversorgungsgeräts, um die Anzahl der am Stromversorgungsgerät anzuschließenden LED zu erfahren.</p> <p>DIE GARANTIE IST GÜLTIG NUR FÜR STRAHLER, DIE MIT I-LèD STROMVERSORGSGERÄTEN ENGESPEIST WERDEN.</p> | <p>Procedimiento de cableado</p> <ol style="list-style-type: none"> 1 Cerrar el interruptor general OFF 2 Conectar los focos al alimentador 3 Conectar el alimentador a la red 4 Abrir el interruptor general ON <p>N.B.</p> <p>Todas las operaciones de mantenimiento e instalación se tendrán que llevar a cabo con el interruptor general en posición OFF</p> <p>No conectar más focos en paralelo a la salida del mismo alimentador</p> <p>Los focos necesitan corriente constante estabilizada</p> <p>Sobre el N° de leds conectables al alimentador seguir las indicaciones indicadas en la etiqueta del mismo</p> <p>EL FOCO SÓLO ESTÁ GARANTIZADO CON ALIMENTADORES DISTRIBUIDOS POR I-LèD</p> |

