

SERIES: PROLAMP 2.0 RGBW

BRAND: i-LÈD



CODICI / CODES

CODICE CODE	Dimensions (LxWxH / Ø x H mm)	POWER (W)	CLASS I / II		WEIGHT (Kg)	CLASS	IP
			INPUT (V)	FREQ. (Hz)			
			CLASS III				
			VOLTAGE (V)	CURRENT (mA)			
C00974	439x795.5x91.8	150	220-240	50/60	6.5	1	67

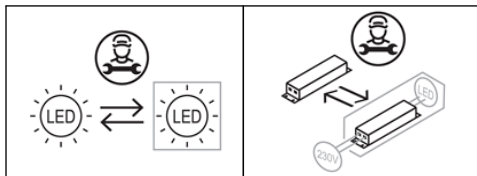

Installazione / Manutenzione

L'articolo dovrà essere installato da personale qualificato, **seguendo le normative d'installazione vigenti del paese di appartenenza**; In caso di malfunzionamento o necessità di manutenzione dell'articolo contattare il servizio clienti Linea Light tramite la seguente mail: support@linealight.com.

SONO SEVERAMENTE VIETATE LE OPERAZIONI DI INSTALLAZIONE E MANUTENZIONE DELL'ARTICOLO MENTRE QUEST ULTIMO È IN FUNZIONE: !!! ATTENZIONE !!! DUARANTE IL FUNZIONAMENTO ALCUNE PARTI DELL'APPARECCHIO POSSONO RAGGIUNGERE TEMPERATURE ELEVATE.

Installation / Maintenance

The article must be installed by qualified personnel, **following the installation regulations in force in your country**; In the event of malfunction or need for maintenance of the article, contact Linea Light customer service via the following e-mail: support@linealight.com.

IT IS STRICTLY FORBIDDEN TO INSTALL AND MAINTAIN THE ARTICLE WHILE IT IS IN OPERATION; !!! WARNING !!! DURING OPERATION, CERTAIN PARTS OF THE APPLIANCE MAY REACH HIGH TEMPERATURES.

LINEA LIGHT declines any kind of responsibility if the instructions provided in the following instruction manual and in the main manual present in the article's packaging are not followed.

UTILIZZO CONFORME:

L'apparecchio è garantito esclusivamente se l'articolo in questione sia stato installato seguendo le istruzioni riportate in questo manuale di istruzioni e da quello generale presenti all'interno dell'imballo e scaricabili dal sito: www.linealight.com; **In caso di mancata osservazione delle precedenti avvertenze, l'azienda LINEA LIGHT declinerà ogni tipologia di responsabilità.**

Un utilizzo scorretto dell'articolo può influire nella durata utile della lampada e/o potrebbe causarne un guasto precoce. Evitare la pulizia dell'apparecchio utilizzando agenti chimici aggressivi, è sufficiente passare l'articolo con uno straccio inumidito con acqua. Per ulteriori avvertenze e/o spiegazioni di eventuali simboli si prega di visionare il foglio istruzioni generale.

CONSERVARE LE PRESENTI ISTRUZIONI PER FUTURI LAVORI DI INSTALLAZIONE/MANUTENZIONE.

COMPLIANT USE:

The luminaire is only guaranteed if the article in question has been installed in accordance with the instructions given in this instruction manual and the general manual found inside the packaging and downloadable from: www.linealight.com; **In the event of failure to comply with the above warnings, LINEA LIGHT declines all liability.**

Incorrect use of the article may affect the service life of the lamp and/or cause it to fail prematurely. Avoid cleaning the fixture using harsh chemicals, simply wipe the item with a cloth dampened with water. For further warnings and/or explanations of possible symbols please refer to the general instruction sheet.

KEEP THESE INSTRUCTIONS FOR FUTURE INSTALLATION/MAINTENANCE WORK.

(ITA) - I prodotti devono essere installati tassativamente con alimentazioni, cablaggi e accessori originali del Gruppo Linea Light, o eventualmente approvati dall'azienda. L'utilizzo di accessori non originali, o non approvati, determina il decadimento di ogni garanzia sul prodotto. (ENG) - All power supply, wiring and accessories used for product installation shall be original Linea Light Group parts or approved by the company. The warranty will become void if non original or non approved parts are used. (FRA) - Les produits doivent impérativement être installés avec des alimentations, des câblages et des accessoires Linea Light Group, ou qui ont été approuvés par l'entreprise. L'utilisation d'accessoires non d'origine, ou non approuvés, entraîne la déchéance de toute garantie sur le produit. (ESP) - Los productos se han de instalar obligatoriamente con alimentaciones, cableados y accesorios originales de Linea Light Group o, de otra forma, deben ser aprobados por la empresa misma. El uso de accesorios no originales, o no aprobados, anula todas las garantías del producto. (GER) Die Produkte müssen obligatorisch mit Originalstromversorgung, Originalkabeln und Originalzubehör der Linea Light Group oder mit Teilen, die von der Linea Light Group ausdrücklich empfohlen sind, installiert werden. Die Verwendung von nicht originale oder nicht vom Hersteller empfohlenem Zubehör führt zu einem sofortigen Verfall vom Garantieanspruch für das Produkt.

SERIES: PROLAMP 2.0 RGBW

BRAND: i-LÈD

**ACCESSORI NON INCLUSI
ACCESSORIES NOT INCLUDED**

**A. CAVO AllinOne DMX
A. AllinOne DMX CABLE**



98660
98661

**B. PROLUNGA CAVO AllinOne DMX
B. EXTENTION CABLE AllinOne DMX**



98662
98663

**C. INIZIALE / START ALLinONE
SPLITTER POWER/DMX**



98985

**D. DI CONTINUITA' / CONTINUITY
ALLinONE SPLITTER POWER/DMX**



99390

**E. CHIUSURA / ENDCAP ALLinONE
POWER/DMX**



98986

**F. CAVO DMX
F. DMX CABLE**



84865

MASTER DMX

G. Stick_DE3 DMX CONTROLLER



99234
99235

**H. Stick_DE3 ALIMENTATORE
H. POWER SUPPLY Stick_DE3**



99184

**I. Stick_DE3 CONTROCASSA
I. Stick_DE3 OUTER CASIN**



98140

L. Stick_GU2 DMX CONTROLLER



99045
99046

**M. Stick_GU2 ALIMENTATORE
M. POWER SUPPLY Stick_GU2**



99184

**N. Stick_GU2 CONTROCASSA
N. Stick_GU2 OUTER CASIN**



98140

O. Slesa_U11 DMX CONTROLLER



83243

**P. Slesa_U11 ALIMENTATORE
P. POWER SUPPLY Slesa_U11**



83244

**Q. Slesa_U11 CONNETTORE XLR 3P
Q. Slesa_U11 XLR 3P CPMMECTOR**



84869

R. Dina_DR1 DMX CONTROLLER



83144

SERIES: PROLAMP 2.0 RGBW

BRAND: **i-LÈD**

DIMENSIONI / DIMENSIONS

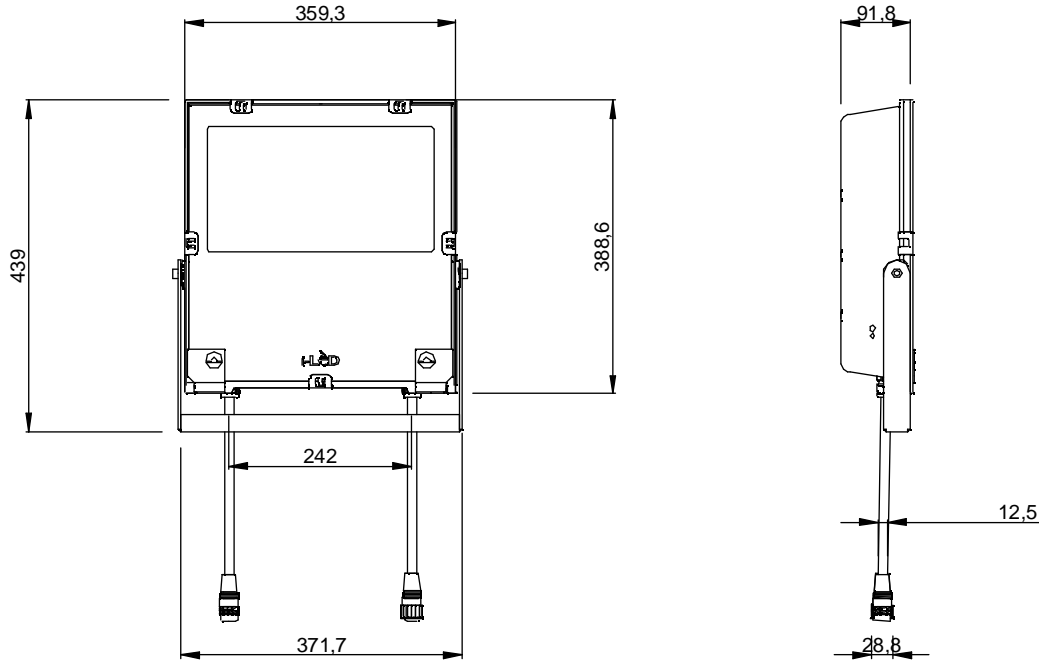

DIMENSIONI STAFFA / BRACKET DIMENSIONS

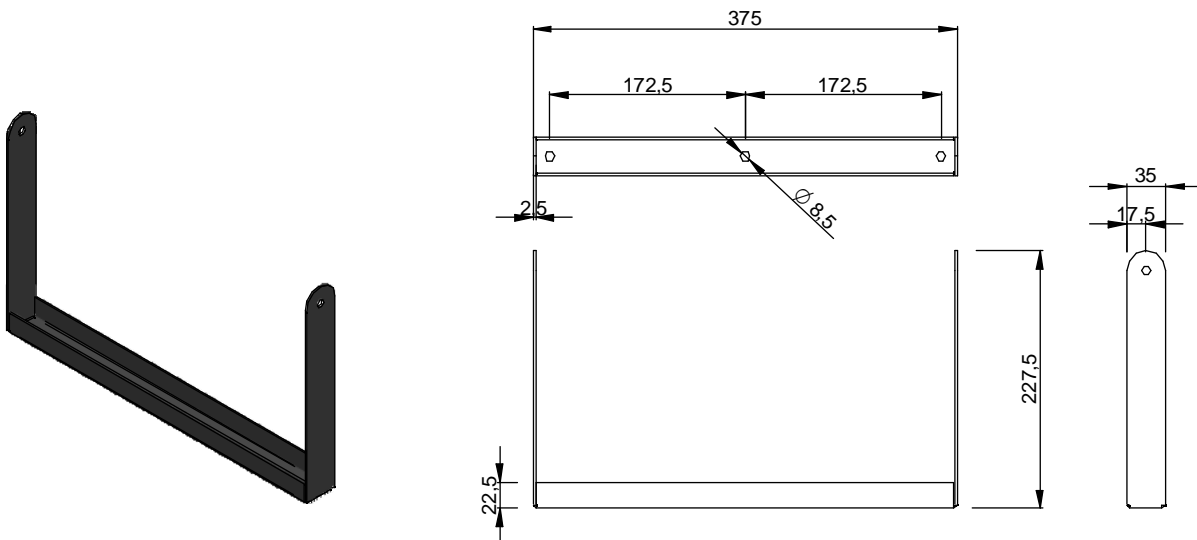

SERIES: PROLAMP 2.0 RGBW

BRAND: i-LèD

PRE-INSTALLAZIONE / PRE-INSTALLATION

ESEGUIRE I FORI DI INSTALLAZIONE DELLA STAFFA SEGUENDO LE MISURE RIPORTATE
MAKE THE INSTALLATION HOLES FOLLOWING PROVIDED DIMENSIONS

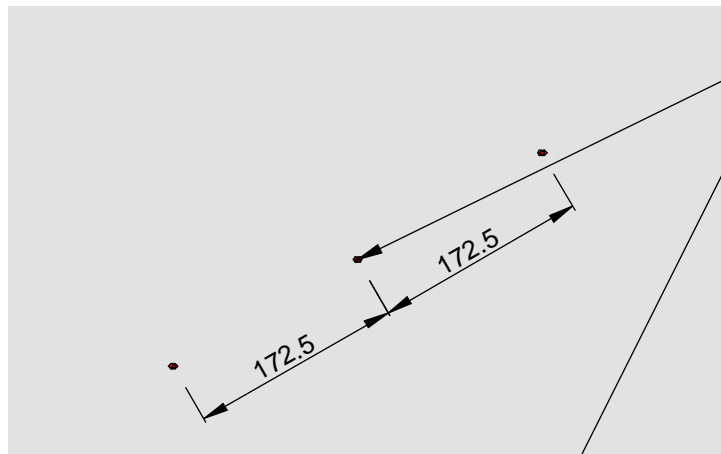

FORI PER LA STAFFA
HOLES FOR BRACKET



VITE PER TASSELLO
ANCHOR SCREW
(NON INCLUSI)
(NOT PROVIDED)

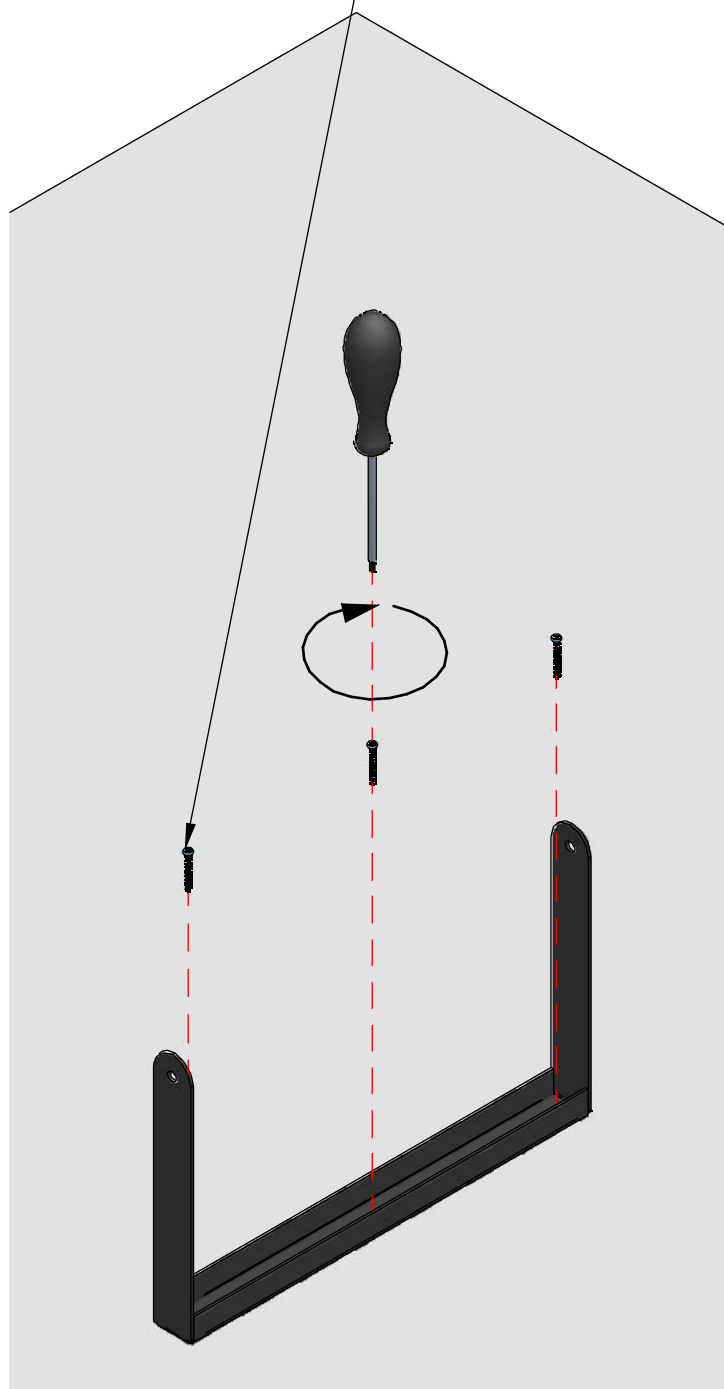

TASSELLI
ANCHORS
(NON INCLUSI)
(NOT PROVIDED)

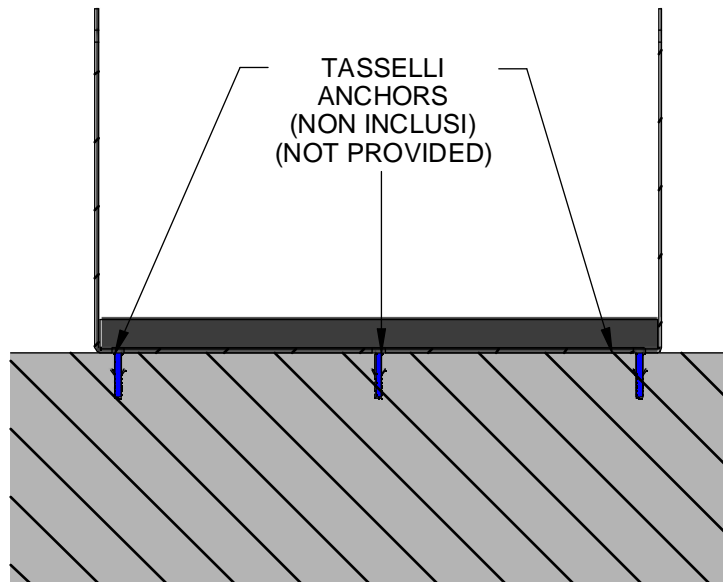

SERIES: PROLAMP 2.0 RGBW

BRAND: i-LèD

INSTALLAZIONE / INSTALLATION

1 INSERIRE IL DORPO ILLUMINANTE SULLA STAFFA AVENDO CURA DI SEGUIRE L'ORDINE DI INSTALLAZIONE DEI COMPONENTI
FIT THE LIGHT FITTING INTO THE BRACKET, MIND THE COMPOMPOENTS INSTALLATION ORDER

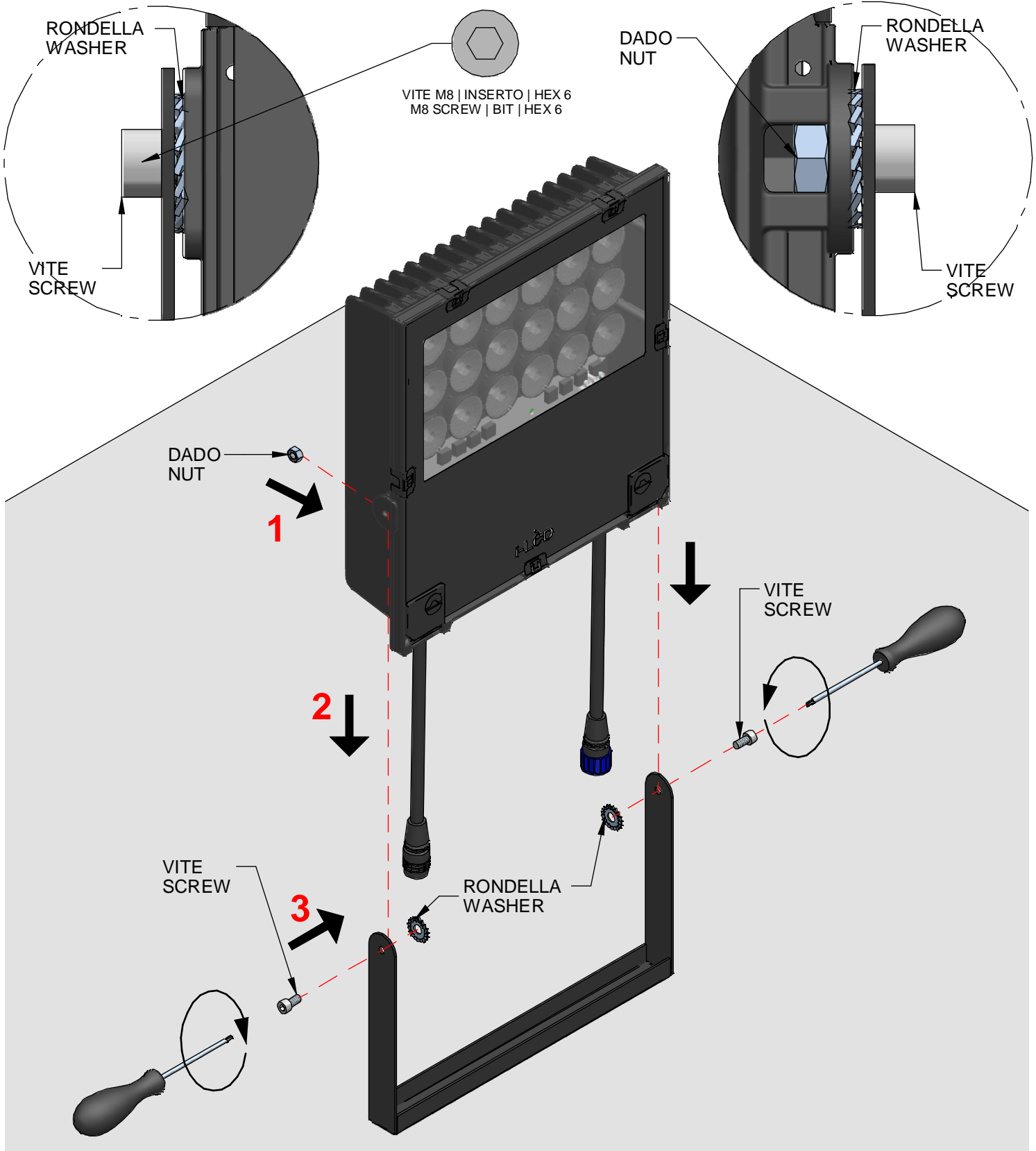

SERIES: PROLAMP 2.0 RGBW

BRAND: i-LÈD

INSTALLAZIONE CORRETTA / PROPER INSTALLATION

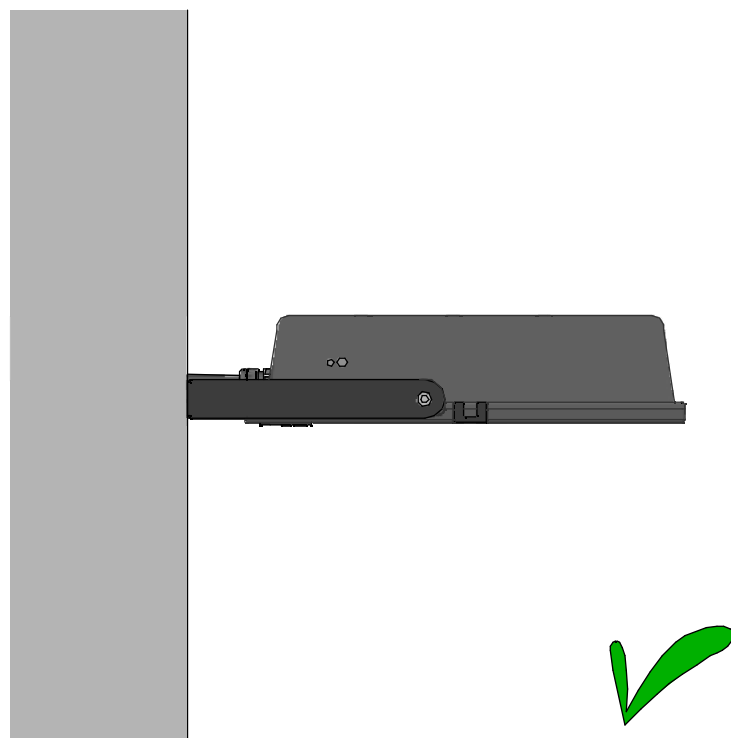
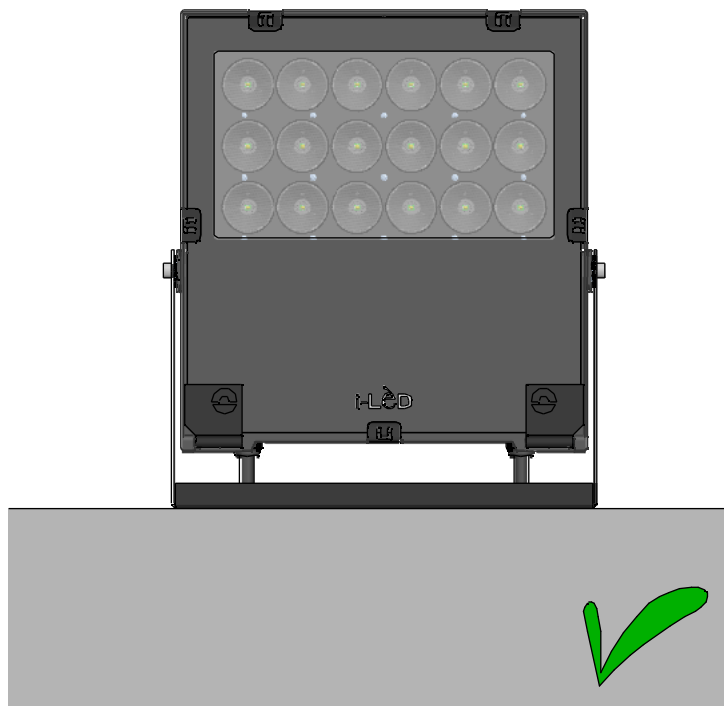

INSTALLAZIONE SCORRETTA / IMPROPER INSTALLATION

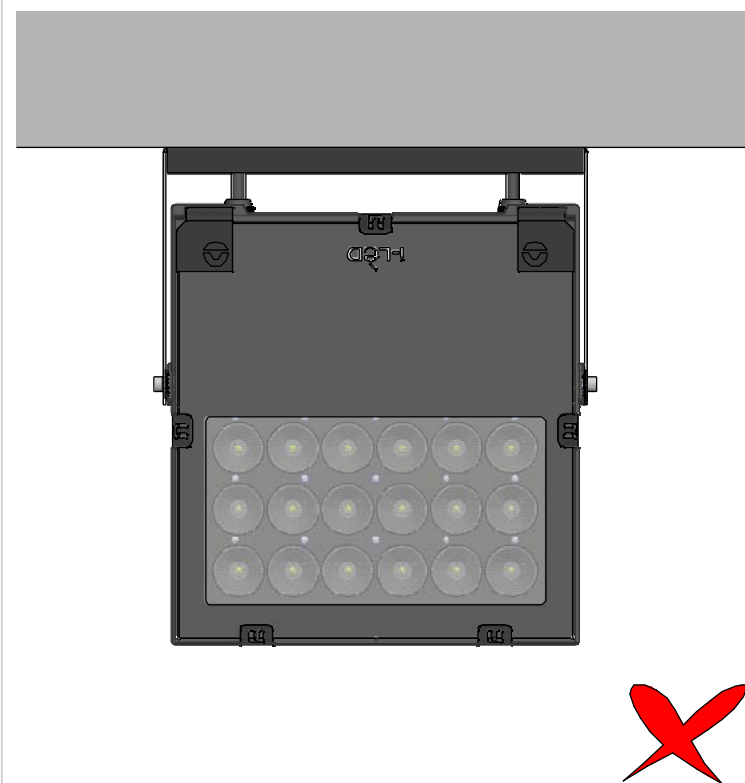
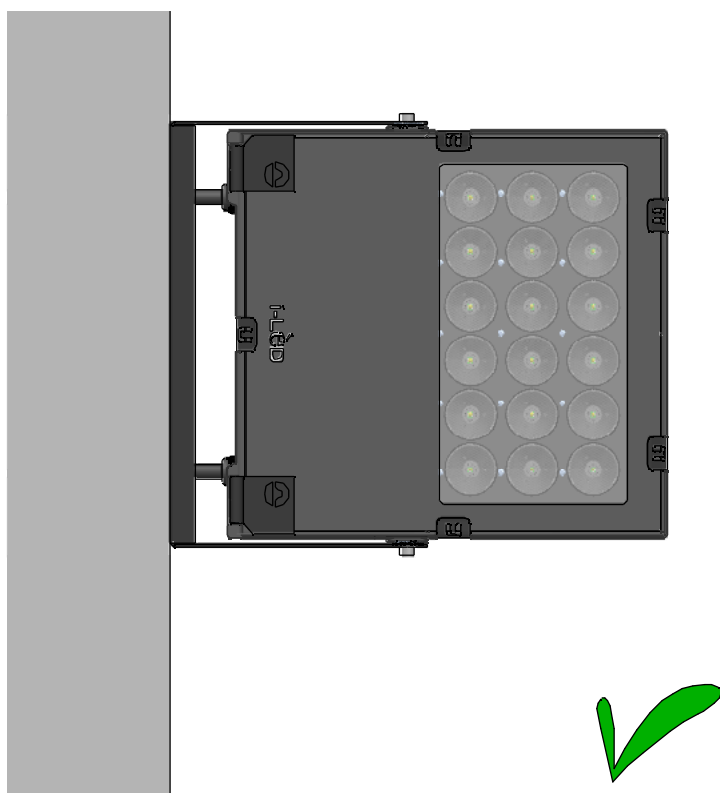







SERIES: PROLAMP 2.0 RGBW

BRAND: i-LÈD

2 COLLEGARE IL PRODOTTO IN SERIE CON ALTRI TRAMITE GLI APPOSITI CAVI NON INCLUSI. INFINE COLLEGARE LA TENSIONE DI RETE
WIRE THE LIGHT FITTING WITH OTHERS IN SERIES USING THE SUGGESTED CABLES (NOT INCLUDED). IN THE END POWER UP THE LINE

**COMBINAZIONE COLI CONDUTTORI
CABLE COLOR CODING**

	BROWN = L/PHASE (Linea/Fase)		RED = DMX+
	BLU = N/Neutral (Neutro)		WHITE = DMX-
	YELLOW/GREEN = GND/GROUND (Terra)		SHIELD = DMX GND

**MAX N° PRODOTTI COLLEGABILE SU MCB
MAX N° FITTINGS UNDER MCB**

CODE	POWER	B10	B16	B20	C10	C16	C20
C00974	150W	2	4	5	4	6	8

**MAX. LUNGHEZZA E SEZIONE CAVO DI ALIMENTAZIONE 230V AC
MAX LENGTH AND SECTION 230V AC POWER CABLE**

SEZIONE SECTION	1.5mm ²	2.5mm ²
LUNGHEZZA LENGTH	75m	130m

