

Tour_Projectors

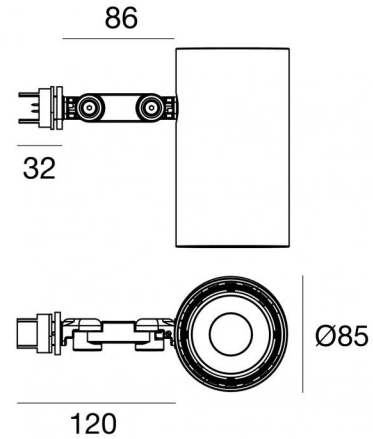

Proyectores | 1 arrayLED 22 W DC 640 mA | CRI 90
82760W30



Datos técnicos	
Tipo	Superficie
Posición de instalación	Techo
Ambiente de instalación	Interiores
Fuente de luz	LED
Circuit structure	arrayLED
Óptica	Flood
Light emission direction	frontal
Potencia nominal	22 W DC
Flujo luminoso (fuente)	3633 lm
CCT / Tone	3000 K
Índice de rendimientos cromático	90 Ra
C.C. / C.V.	DC
Clase de aislamiento	2
IP	IP20
Test del hilo incandescente	850°
Montaje directo sobre superficies normalmente inflamables	Sí
CE	Sí
Artículo regulable	No
Orientabilidad	Orientabile
ángulo total (plano vertical)	180 °
ángulo total (plano horizontal)	360 °
Basculación	No
Practicabilidad	No
Transitabilidad	No
Cable incluido.	No
Resinado	No
Tipología de emisión luminosa	Una emisión
Peso neto	0.9 Kg
Protección descargas electrostáticas	No
Protección contra sobretensiones	No

Acabado cuerpo	
Material	aluminio
Color	Negro
Elaboración	Pintura



Proyectores | 1 arrayLED 22 W DC 640 mA | CRI 90
82760W30

Single emission projectors for indoor application. The warm white LED light source with a flood light distribution is composed of 1 arrayed LEDs with CCT of 3000 K and a CRI 90; the source luminous flux is 3633 lm, with a 165.1 lm/W nominal luminous efficacy.

The device body is made of aluminium and features a black finish, processed by means of coating. The ingress protection degree is IP20; the total weight is of 0.9 kg.

The total absorbed power is 22 W.

The device features protection class II and can be ceiling-mounted.

Compliant with the EN 60598-1 standard and its specific provisions.

Clase de eficiencia energética

Este producto contiene una fuente de luz de clase de eficiencia energética E.

Características Luminotécnicas

Light Output Ratio (LOR)	74 %
Flujo luminoso (fuente)	3633 lm
Flujo luminoso de luminaria	2719 lm
Consumption	22 W
Rendimiento luminoso de las luminarias	123 lm/W
Temperatura de color	3000 K
Standard Deviation of Colour Matching	2 Step MacAdam
Índice de rendimientos cromático	90 Ra
Colour Rendering Index	60 R9
Black Body Locus	On
Temperatura estándar del ambiente de servicio	-20 / +50°C

LED Life / Failure Ratio

L70 B10 C0 252000h (at Tj 65 Ta 25)

UGR

UGR transversal	16
UGR axial	15.9
X=4H Y=8H	S=0.25H
Reflection factor	70/50/20

OPTICAL

Óptica C0/C180	24°
Light distribution simmetry	Symmetrical

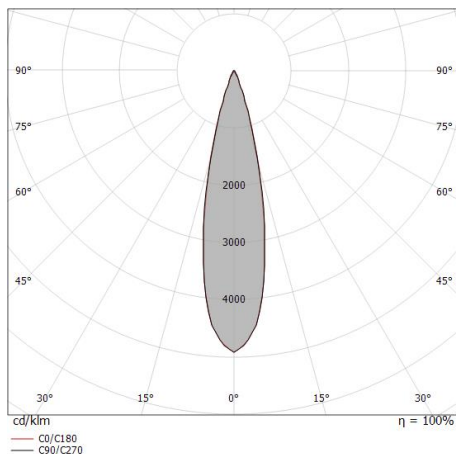

Distance [m]	Cone diameter [m]	illuminance [lx]
0.5	0.21 0.21	E(0°) 53509 E(C90) 12.0° 25115 E(C0) 11.9° 25226
1.0	0.43 0.42	E(0°) 13377 E(C90) 12.0° 6279 E(C0) 11.9° 6306
1.5	0.64 0.63	E(0°) 5945 E(C90) 12.0° 2791 E(C0) 11.9° 2803
2.0	0.85 0.84	E(0°) 3344 E(C90) 12.0° 1570 E(C0) 11.9° 1577
2.5	1.06 1.05	E(0°) 2140 E(C90) 12.0° 1005 E(C0) 11.9° 1009
3.0	1.28 1.26	E(0°) 1486 E(C90) 12.0° 698 E(C0) 11.9° 701

— C0/C180 (Half-peak divergence: 23.8°)
— C90/C270 (Half-peak divergence: 24.0°)

COLOR VECTOR GRAPHIC





Proyectoros | 1 arrayLED 22 W DC 640 mA | CRI 90
82760W30

Components

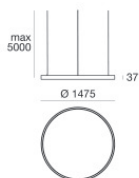

Tour_Track

Code

82753 - 82756 - 82755 - 82754



antideslumbramiento
Tipo antideslumbrante: louver de nido de abeja.
Material:Pom-C, color:Negro.

Code
C-U300008



antideslumbramiento
Tipo antideslumbrante: schermo cilindrico 45°.
Material:Pom-C, color:Negro.

Code
C-U300030

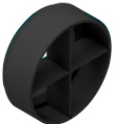

antideslumbramiento
Tipo antideslumbrante: frangiluce a croce.
Material:Pom-C, color:Negro.

Code
C-U300031

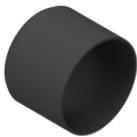

antideslumbramiento
Tipo antideslumbrante: schermo cilindrico.
Material:Pom-C, color:Negro.

Code
C-U300029



Difusor
Tipo de difusor: filtro ellittico

Code
C-U300007



Óptica - SPOT
Distribución de la luz: spot,Material de revestimiento: policarbonato resistente a los rayos uv

Code
C-U300015



Óptica - FLOOD
Distribución de la luz: flood,Material de revestimiento: ,policarbonato resistente a los rayos uv,policarbonato resistente a los rayos uv,policarbonato resistente a los rayos uv

Code
C-U300016



Óptica - WIDE FLOOD
Distribución de la luz: medium flood,Material de revestimiento: ,policarbonato resistente a los rayos uv,policarbonato resistente a los rayos uv,policarbonato resistente a los rayos uv

Code
C-U300017