

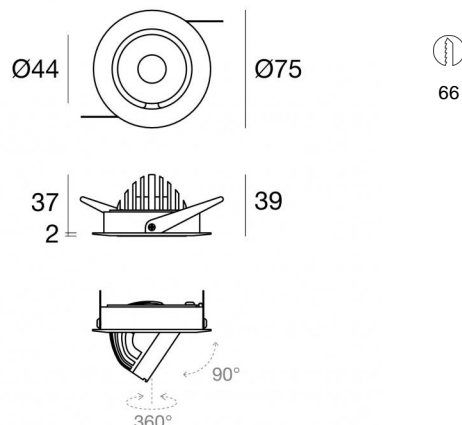

Downlights | 1 x powerLED 4 W DC 350 mA | CRI 90  
**82740N60**





Datos técnicos	
Posición de instalación	Techo
Ambiente de instalación	Interiores
Fuente de luz	LED
Circuit structure	powerLED
Óptica	Wide Flood
Light emission direction	downward
Potencia nominal	4 W DC
Flujo luminoso (fuente)	449 lm
Rango de voltaje de entrada	350mA
CCT / Tone	4000 K
Índice de rendimientos cromático	90 Ra
C.C. / C.V.	CC
Clase de aislamiento	3
IP	IP20
Test del hilo incandescente	850°
Montaje directo sobre superficies normalmente inflamables	Sí
CE	Sí
Driver incluido.	No
Artículo regulable	DALI - 1-10V
Orientabilidad	Estraible
ángulo total (plano vertical)	90 °
ángulo total (plano horizontal)	360 °
Basculación	No
Practicabilidad	No
Transitabilidad	No
Cable incluido.	Sí
Largo del cable	0.2 m
Resinado	No
Tipología de emisión luminosa	Una emisión
Peso neto	0.1 Kg
Protección descargas electrostáticas	No
Protección contra sobretensiones	No

### Acabado cuerpo

Material	Aluminio fundido EN AB - 46100
Color	Negro
Elaboración	Recubrimiento en polvo

### Electrónica

 89145  
On/Off Driver 198~264V AC / 180~275V DC

 99375  
On/Off Driver 198~264V AC

 C-E100010  
1-10V - 0-10V Controller

 C-E100011  
Push and Simply Dim - DALI-2 Controller

## Downlights | 1 x powerLED 4 W DC 350 mA | CRI 90 82740N60

Single emission recessed downlights for indoor application. The natural white LED light source with a wide flood light distribution is composed of 1 powerLED LEDs with CCT of 4000 K and a CRI 90; the source luminous flux is 449 lm, with a 112.3 lm/W nominal luminous efficacy.

The device body is made of die-cast aluminium en ab - 46100 and features a black finish, processed by means of powder coating. The ingress protection degree is IP20; the total weight is of 0.1 kg. The power supply driver is not provided and is to be ordered separately.

The total absorbed power is 4 W. The power supply cable is included and features a 0.2 m length.

The device features protection class III and can be ceiling-mounted, with a 66 mm diameter hole (in plasterboard).

Compliant with the EN 60598-1 standard and its specific provisions.

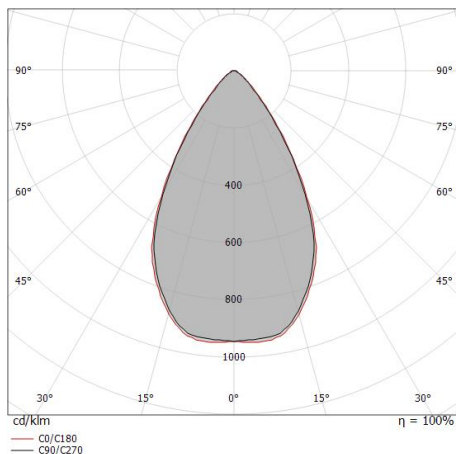

Distance [m]	Cone diameter [m]	illuminance [lx]
0.5	0.59 0.60	E(0°) 1237 E(C90) 396 E(C0) 394
1.0	1.18 1.20	E(0°) 309 E(C90) 99 E(C0) 99
1.5	1.77 1.80	E(0°) 137 E(C90) 44 E(C0) 44
2.0	2.37 2.38	E(0°) 77 E(C90) 25 E(C0) 25
2.5	2.96 2.99	E(0°) 49 E(C90) 16 E(C0) 16
3.0	3.55 3.59	E(0°) 34 E(C90) 11 E(C0) 11

— C0/C180 (Half-peak divergence: 61.8°)  
— C90/C270 (Half-peak divergence: 61.2°)

### Clase de eficiencia energética

Este producto contiene una fuente de luz de clase de eficiencia energética F.

### Características Luminotécnicas

Light Output Ratio (LOR)	72 %
Flujo luminoso (fuente)	449 lm
Flujo luminoso de luminaria	327 lm
Consumption	4 W
Rendimiento luminoso de las luminarias	81 lm/W
Temperatura de color	4000 K
Standard Deviation of Colour Matching	3 Step MacAdam
Índice de rendimientos cromático	90 Ra
Black Body Locus	On
Temperatura estándar del ambiente de servicio	-20 / +50°C
Temperatura típica sobre el vidrio	40°C

### LED Life / Failure Ratio

L70 B10 C0 247450h (at Tj 60 Ta 25 )

### UGR

UGR axial	26.8
UGR transversal	26.9
X=4H   Y=8H	S=0.25H
Reflection factor	70/50/20

### OPTICAL

Óptica C0/C180	61°
Light distribution simmetry	Symmetrical

