

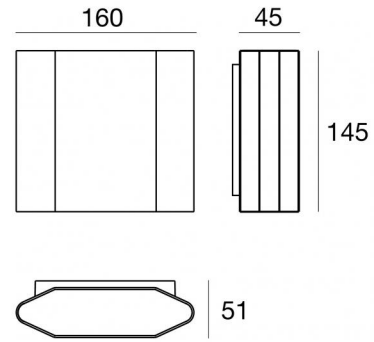

Luminaria de pared | 176-264 V AC /176-280 V DC
72 topLED 14.4 W DC - 16 W AC | CRI 80
76950M00



Datos técnicos	
Tipo	Superficie
Posición de instalación	Pared
Ambiente de instalación	Exteriores
Fuente de luz	LED
Circuit structure	topLED
Óptica	Double Diffused
Light emission direction	downward and upward
Potencia nominal	14.4 W DC
Poder total	16 W
Flujo luminoso (fuente)	2388 lm
Tensión nominal de entrada	220 - 240 V AC
Rango de voltaje de entrada	176 - 264 V AC
Frequency	50 - 60 Hz
CCT / Tone	2700 K
Índice de rendimientos cromático	80 Ra
C.C. / C.V.	AC
Clase de aislamiento	1
IP	IP65
IK	IK06
Test del hilo incandescente	850°
Montaje directo sobre superficies normalmente inflamables	No
CE	Sí
Driver incluido.	driver
Artículo regulable	No
Orientabilidad	No
Basculación	No
Practicabilidad	No
Transitabilidad	No
Cable incluido.	No
Resinado	No
Tipología de emisión luminosa	Dos emisiones
Peso neto	1.11 Kg
Protección descargas electrostáticas	Sí
Protección contra sobretensiones	0.5 KV

Acabado cuerpo	
Material	Aluminio fundido EN AB - 46100
Color	gris
Elaboración	Recubrimiento en polvo
Acabado difusor	
Material	Vidrio extra claro
Acabado abrazadera	
Material	Acero AISI 304
Color	acero

La fuente de alimentación contenida en el dispositivo cumple con la norma IEC 61347-2-13 anexo J y, por lo tanto, puede alimentarse mediante sistemas de alimentación centralizados.



Luminaria de pared | 176-264 V AC /176-280 V DC | 72 topLED 14.4 W DC - 16 W AC | CRI 80
76950M00

Double emission wall lights for outdoor application. The super warm white LED light source with a double diffused light distribution is composed of 72 topLED LEDs with CCT of 2700 K and a CRI 80; the source luminous flux is 2388 lm, with a 165.8 lm/W nominal luminous efficacy.

The device body is made of die-cast aluminium en ab - 46100 and features a grey ral 7021 finish, processed by means of powder coating; the diffuser is made of extra clear glass. The ingress protection degree is IP65; the total weight is of 1.11 kg.

The total absorbed power is 16 W.

The device features protection class I and can be wall lights-mounted.

Compliant with the EN 60598-1 standard and its specific provisions.

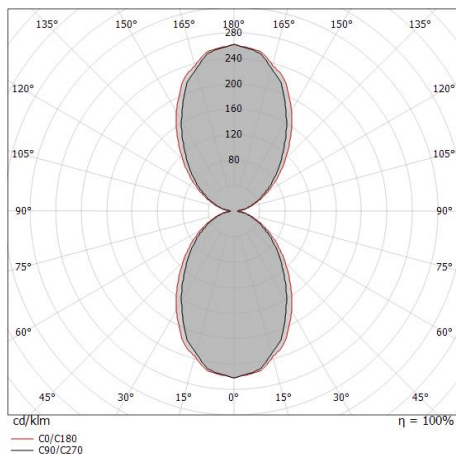

Clase de eficiencia energética

Este producto contiene 2 fuentes de luz de clase de eficiencia energética D.

Características Luminotécnicas

Light Output Ratio (LOR)	37 %
Flujo luminoso (fuente)	2388 lm
Flujo luminoso de luminaria	900 lm
Consumption	16 W
Rendimiento luminoso de las luminarias	56 lm/W
Temperatura de color	2700 K
Standard Deviation of Colour Matching	3 Step MacAdam
Índice de rendimientos cromático	80 Ra

Temperatura estándar del ambiente de servicio	-20 / +50°C
Temperatura típica sobre el vidrio	40°C

LED Life / Failure Ratio

L70 B10 C0 145770h (at Tj 65 Ta 25)

OPTICAL

Óptica C90/C270	74°
Óptica C0/C180	82°
Light distribution simmetry	Symmetrical 2 assis