

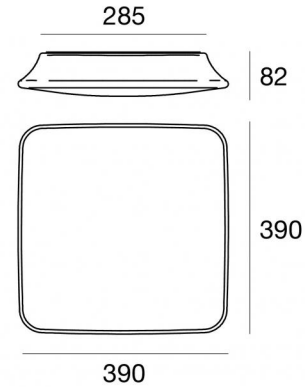

Ceiling Downlights | 220-240 V
1 topLED 12 W DC - 16 W AC | CRI 85
7808



Technical data	
Construction year	2015
Type	Surface
Installation position	Wall lights - Ceiling
Installation environment	Indoor - Outdoor
Light Source	LED
Circuit structure	topLED
Optics	Diffused
Light emission direction	frontal
Nominal power	12 W DC
Total Power	16 W
Source lumens	1396 lm
Nominal input voltage	220 - 240 V AC
Input voltage range	220 - 240 V AC
Frequency	50 - 60 Hz
CCT / Tone	3000 K
Colour rendering index	85 Ra
C.C. / C.V.	AC
Safety class	2
IP	IP65
IK	IK10
Glow wire test	650°
Direct mounting on normally flammable surfaces	Yes
CE	Yes
Driver included	Driver
Dimmable article	No
Directional	No
Tilting	No
Walk-over	No
Drive-over	No
Cable included	No
Resin potting	No
Type of light emission	Double emission
Net weight	1.975 Kg
Electrostatic discharge protection	No
Surge protection	No

Finishing diffuser	
Material	PE
Colour	neutral

Finishing mounting frame	
Material	PC
Colour	white

The driver contained in the device complies with IEC 61347-2-13 annex J, and can therefore be powered by centralized power systems.



Ceiling Downlights | 220-240 V | 1 topLED 12 W DC - 16 W AC | CRI 85 | Base 7808

Double emission ceiling downlights for indoor or outdoor application. The warm white LED light source with a diffused light distribution is composed of 72 topLEDs with CCT of 3000 K and a CRI 85; the source luminous flux is 1396 lm, with a 116.3 lm/W nominal luminous efficacy.

The diffuser is made of pe; the mounting frame is made of PC, with a white finish. The ingress protection degree is IP65; the total weight is of 1.975 kg.

The total absorbed power is 16 W.

The device features protection class II and can be wall lights or ceiling-mounted.

Compliant with the EN 60598-1 standard and its specific provisions.

Energy efficiency class

This product contains a light source of energy efficiency class F.

Illuminotechnical Features

Light Output Ratio (LOR)	82 %
Source lumens	1396 lm
Delivered lumens	1150 lm
Consumption	16 W
Luminaire efficacy	71 lm/W
Colour temperature	3000 K
Standard Deviation of Colour Matching	3 Step MacAdam
Colour rendering index	85 Ra
Junction temperature (lighting fixture)	80

Standard Operating Ambient Temperature -20 / +50°C

LED Life / Failure Ratio

L70 B20 C0 72500h

UGR

UGR axial	14.6
UGR transversal	14.9
X=4H Y=8H	S=0.25H
Reflection factor	70/50/20

OPTICAL

C0/C180 optics	114°
Light distribution simmetry	Symmetrical

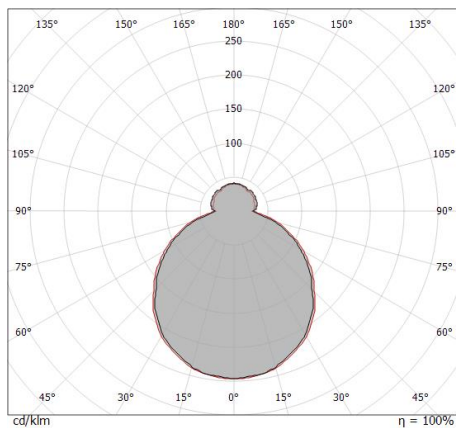

Distance [m]	Cone diameter [m]	Beam diameter [m]	E(0°) [lx]	E(C90) [lx]	E(C0) [lx]
0.5	1.54 1.64	1.54 1.64	1134	92	80
1.0	3.08 3.29	3.08 3.29	283	23	20
1.5	4.62 4.93	4.62 4.93	126	10	9
2.0	6.16 6.58	6.16 6.58	71	6	5
2.5	7.70 8.22	7.70 8.22	45	4	3
3.0	9.24 9.87	9.24 9.87	31	3	2

Distance [m] Cone diameter [m] Illuminance [lx]

— C0/C180 (Half-peak divergence: 117.4°)
— C90/C270 (Half-peak divergence: 114.0°)