

Serie : COB20_Q / COB65_Q

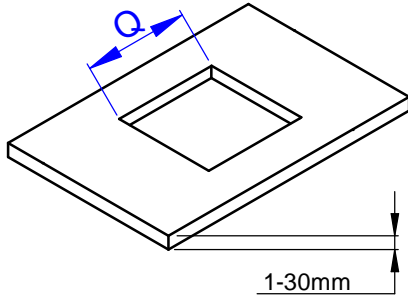

TYPE	L (mm)	Q (mm)
COB20_Q	140	122X122
	175	157X157
	205	188X188
COB65_Q	140	122X122
	175	157X157
	205	188X188

!
Spegnere l'interruttore generale
Switch off the main switch

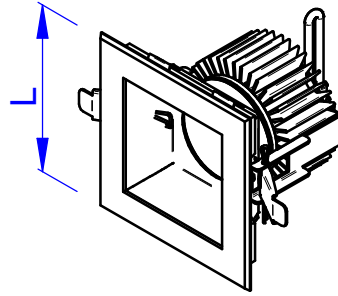
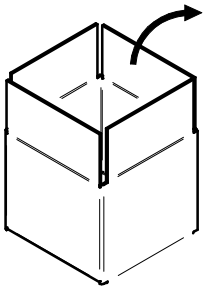
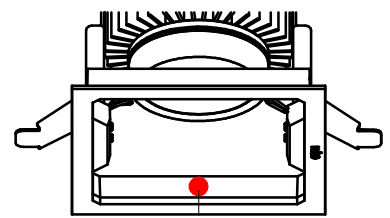
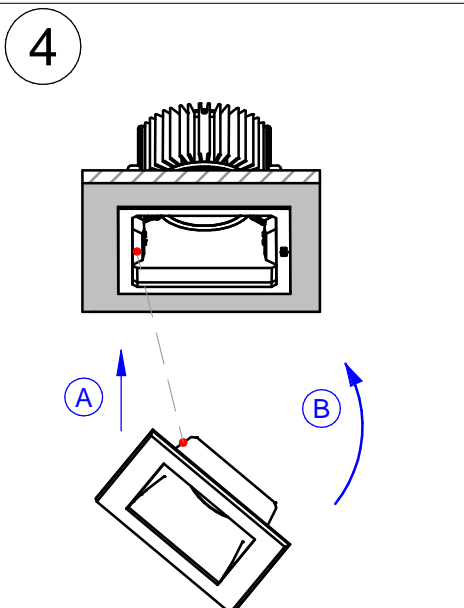
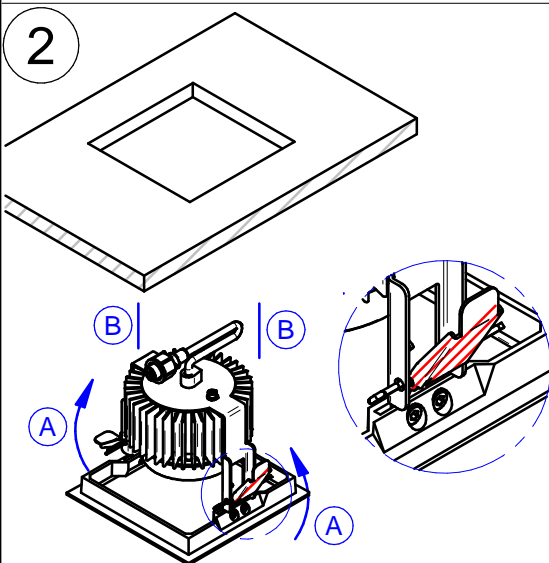
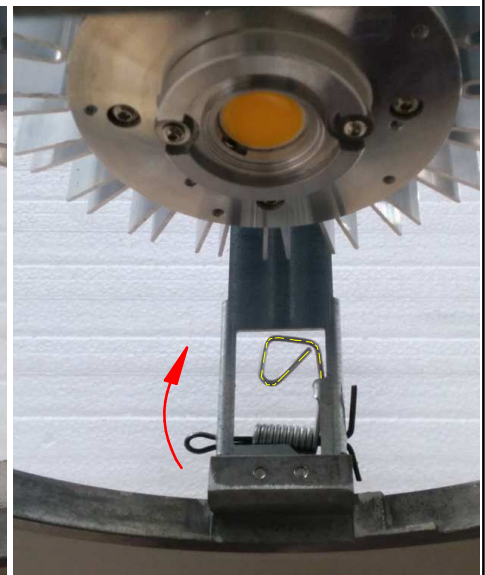
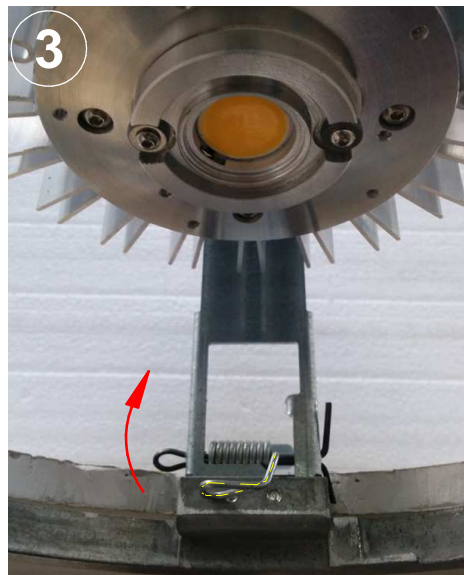
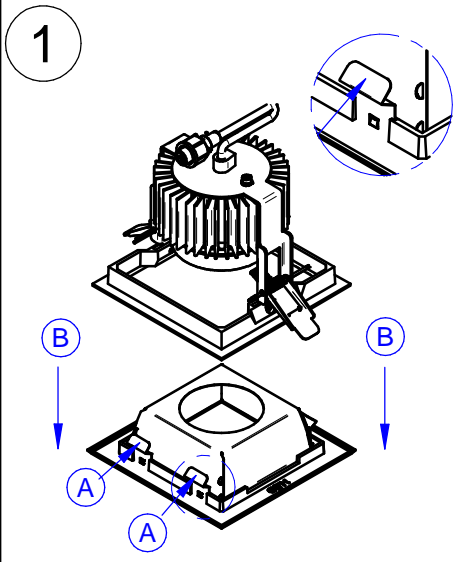
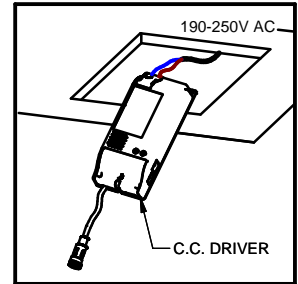

ATTENZIONE!!
POSIZIONARE LA FLANGIA CENTRALE FACENDO COMBACIARE I DUE BOLLINI.
WARNING !!
YOU MUST PLACE THE FLANGE SO THAT THE TWO STICKERS MATCH UP.

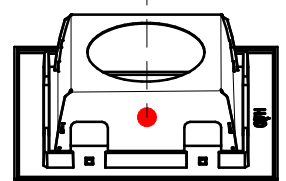

ISTRUZIONI DI MONTAGGIO - MOUNTING INSTRUCTIONS

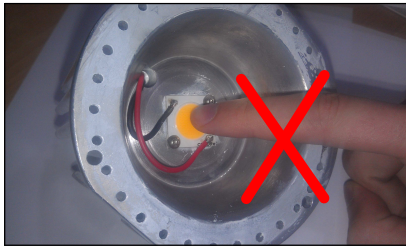

ATTENZIONE!!
 NON TOCCARE LA SORGENTE LUMINOSA CON LE DITA O CON QUALSIASI ALTRO UTENSILE PERCHE' POTREBBE CAUSARE IL MALFUNZIONAMENTO O LA ROTTURA DEL LED. L'AZIENDA NON RISPONDE IN CASO DI DANNI ARRECATI SE NON SI RISPETTA QUESTA INDICAZIONE.

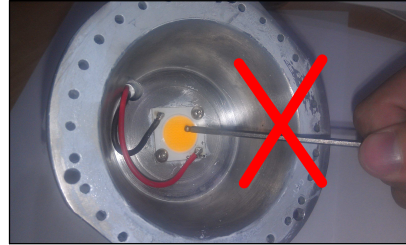

WARNING!
 DO NOT TOUCH THE LAMP WITH YOUR FINGERS OR ANY OTHER TOOL WHY 'COULD CAUSE THE MALFUNCTION OR BREAK LED. THE COMPANY IS NOT RESPONSIBLE FOR ANY DAMAGE CAUSED IF YOU DO NOT RESPECT THIS STATEMENT.

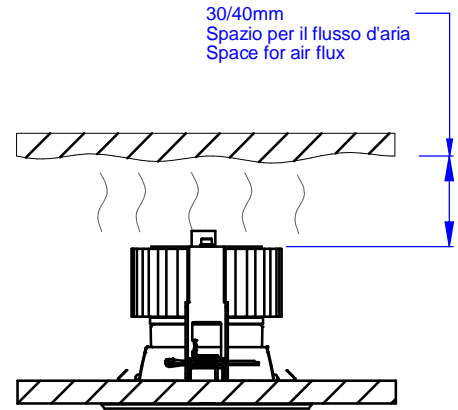

I	GB	F	D	E
<p>Procedura di cablaggio</p> <p>1 Chiudere l' interruttore generale OFF</p> <p>2 Collegare i faretti all' alimentatore</p> <p>3 Collegare l' alimentatore alla rete</p> <p>4 Aprire l' interruttore generale ON</p> <p>N.B</p> <p>Tutte le operazioni di manutenzione ed installazione vanno eseguite con l' interruttore generale in posizione OFF</p> <p>Non collegare più faretti in parallelo all' uscita dello stesso alimentatore</p> <p>I faretti necessitano di corrente costante stabilizzata</p> <p>Per il N° di led collegabili all' alimentatore seguire le indicazioni sull'etichetta dello stesso</p> <p>IL FARETTO RISULTA GARANTITO SOLO CON ALIMENTATORI DISTRIBUITI DA i-LèD</p>	<p>Wiring procedure</p> <p>1 Switch off the main switch OFF</p> <p>2 Connect the spotlights to the power supply unit.</p> <p>3 Connect the power supply unit to the network</p> <p>4 Switch on the main switch ON</p> <p>N.B</p> <p>All the maintenance and installation procedures must be carried out with the main switch in position OFF</p> <p>Do not connect too many parallel spotlights to the output of the same power supply unit</p> <p>Use stabilized constant current for the spotlights</p> <p>Follow the instructions on the label of the power supply unit for the number of spotlights that can be connected to it</p> <p>SPOTLIGHTS ARE GUARANTEED ONLY IF POWER SUPPLY UNITS DISTRIBUTED BY i-LèD ARE USED</p>	<p>Procédure de câblage</p> <p>1 Couper le disjoncteur OFF</p> <p>2 Relier les spots au driver</p> <p>3 Relier le driver au réseau</p> <p>4 Connecter le disjoncteur ON</p> <p>N.B.</p> <p>Toutes les opérations de maintenance et d'installation seront effectuées avec le disjoncteur sur la position OFF</p> <p>Ne pas relier plusieurs spots en parallèle sur la sortie du même driver</p> <p>Les spots nécessitent d'un courant constant stabilisé</p> <p>Pour le N° de leds reliables au driver, suivre les indications reportées sur son étiquette</p> <p>LE SPOT EST GARANTI SEULEMENT AVEC LES DRIVERS DISTRIBUES PAR i-LèD</p>	<p>Anleitung zur Verkabelung</p> <p>1 Schalten Sie den Hauptschalter aus OFF</p> <p>2 Schliessen Sie die Strahler an dem Stromversorgungsgeraet an</p> <p>3 Schliessen Sie das Stromversorgungsgeraet ans Netz an</p> <p>4 Schalten Sie den Hauptschalter ein ON</p> <p>N.B</p> <p>Die Wartungs- und Instandhaltungsvorgänge müssen mit Hauptschalter in Position durchgeführt werden OFF</p> <p>Schalten Sie weiterhin keinen Strahler mehr parallel am Ausgang desselben Stromversorgungsgeräts</p> <p>Die Strahler brauchen Konstantstrom</p> <p>Beachten Sie die Etikette des Stromversorgungsgeräts, um die Anzahl der am Stromversorgungsgerät anzuschliessenden LED zu erfahren.</p> <p>DIE GARANTIE IST GÜLTIG NUR FÜR STRAHLER, DIE MIT i-LèD STROMVERSORGUNGSGERÄTEN ENGESPEIST WERDEN.</p>	<p>Procedimiento de cableado</p> <p>1 Cerrar el interruptor general OFF</p> <p>2 Conectar los focos al alimentador</p> <p>3 Conectar el alimentador a la red</p> <p>4 Abrir el interruptor general ON</p> <p>N.B</p> <p>Todas las operaciones de mantenimiento e instalación se tendrán que llevar a cabo con el interruptor general en posición OFF</p> <p>No conectar má focos en paralelo a la salida del mismo alimentador</p> <p>Los focos necesitan corriente constante estabilizada</p> <p>Sobre el N° de leds conectables al alimentador seguir las indicaciones indicadas en la etiqueta del mismo</p> <p>EL FOCO SÓLO ESTÁ GARANTIZADO CON ALIMENTADORES DISTRIBUIDOS POR i-LèD</p>

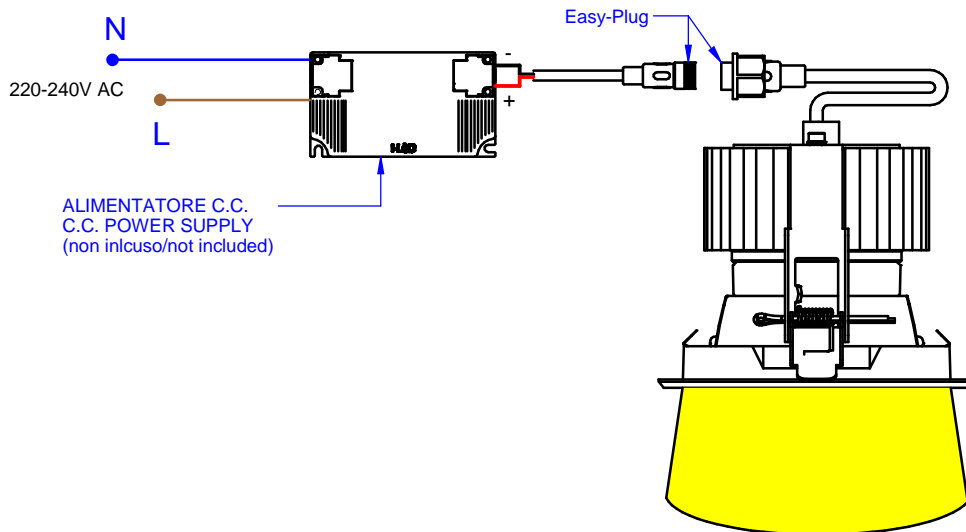

(ITA) - I prodotti devono essere installati tassativamente con alimentazioni, cablaggi e accessori originali del Gruppo Linea Light, o eventualmente approvati dall'azienda. L'utilizzo di accessori non originali, o non approvati, determina il decadimento di ogni garanzia sul prodotto. (ENG) - All power supply, wiring and accessories used for product installation shall be original Linea Light Group parts or approved by the company. The warranty will become void if non original or non approved parts are used. (FRA) - Les produits doivent impérativement être installés avec des alimentations, des câblages et des accessoires Linea Light Group, ou qui ont été approuvés par l'entreprise. L'utilisation d'accessoires non d'origine, ou non approuvés, entraîne la déchéance de toute garantie sur le produit. (ESP) - Los productos se han de instalar obligatoriamente con alimentaciones, cableados y accesorios originales de Linea Light Group o, de otra forma, deben ser aprobados por la empresa misma. El uso de accesorios no originales, o no aprobados, anula todas las garantías del producto. (GER) Die Produkte müssen obligatorisch mit Originalstromversorgung, Originalkabeln und Originalzubehör der Linea Light Group oder mit Teilen, die von der Linea Light Group ausdrücklich empfohlen sind, installiert werden. Die Verwendung von nicht originale oder nicht vom Hersteller empfohlenem Zubehör führt zu einem sofortigen Verfall vom Garantieanspruch für das Produkt.