

ISTRUZIONI DI MONTAGGIO - MOUNTING INSTRUCTIONS

Serie : **WARP; WARP-Y; VOS-R; VOS-Q; VOS-QY; VOS-RJ; VOS-QJ; VOS-QY**



LED-FGI453



I
L'APPARECCHIO DEVE ESSERE INSTALLATO DA PERSONALE QUALIFICATO.
L'AZIENDA DECLINA OGNI RESPONSABILITÀ QUALORAL'INSTALLAZIONE NON AVVENGA SECONDO LE NORME VIGENTI.
LASCIARE UNA COPIA DI QUESTE ISTRUZIONI AL RESPONSABILE DELLA MANUTENZIONE.
CONSERVARE L'ETICHETTA DELL'IMBALLLO ORIGINALE PER EVENTUALI RECLAMI FUTURI.

GB
THIS FICTURE MUST BE INSTALLED BY A QUALIFICATED ELECTRICIAN.
LINEA LIGHT IS NOT RESPONSIBLE IF ITS FIXTURES ARE NOT INSTALLED ACCORDING TO LOCAL SAFETY STANDARDS.
PLEASE LEAVE A COPY OF THESE INSTRUTIONS TO THE PERSON RESPONSABLE FOR THE MAINTENANCE OF THE INSTALLATION.
KEEP THE LABEL OF THE ORIGINAL PACKING FOR THE EVENTUAL FUTURE CLAIMS.

F
L'APPREIL DOIT ETRE INSTALLE PAR ELECTRICIENS QUALIFIES.
LINEA LIGHT NE PEUT PAS ETRE RESPONSABLE POUR TOUTES INSTALLATIONS QUI NE RESPECTENT PAS LES NORMES DE SECURITE EN VIGUER.
LAISSER UNE COPIE DE CES INSTRUCTIONS AU RESPONSABLE DE L'ENTRETIEN DU SYSTEME.
GARDER L'ETIQUETTE DE L'EMBALLAGE ORIGINAL POUR EVENTUELLES RECLAMATIONS FUTURES.

D
DAS GERÄT MUSS VON ELEKTROINSTALLATEUREN MONTIERT WERDEN.
LINEA LIGHT IST NICHT VERANTWORTLICH WENN DIE MONTAGE NICHT GEMÄß DER SICHERHEITSVORSCHRIFTEN STATTFINDET.
DIESES HINWEISBLATT MUß VOM INSTANDHALTUNGSLERER AUFBEWAHRT WERDEN.
BEI REKLAMATIONEN BITTE DEN ARTIKELAUFKLEBER AUS DER LEUCHTENVERPACKUNG BEIFÜGEN.

E
EL APARATO DEBE SER INSTALADO POR ELECTRICISTAS CUALIFICADOS.
LINEA LIGHT NO SE RESPONSABILIZARA DE TODAS LAS INSTALACIONES QUE NO RESPETEN LAS NORMAS DA SEGURIDAD EN VIGOR.
ENTREGAR UNA COPIA DE ESTAS INSTRUCCIONES AL RESPONSABLE DE LA INSTALACION.
CONSERVAR LA ETIQUETA DEL EMBALAJE ORIGINAL PARA POSIBLES RECLAMACIONES.

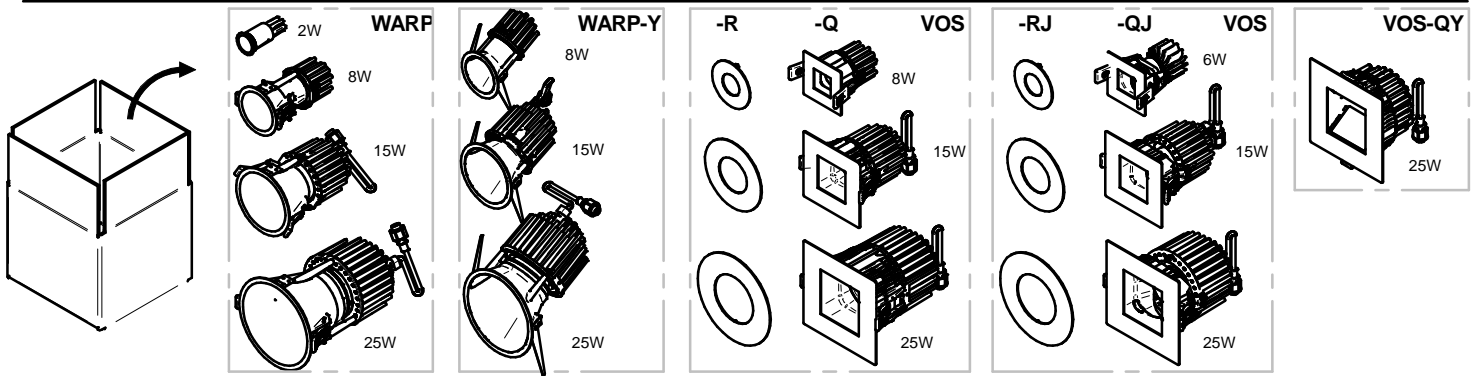

ISTRUZIONI / INSTRUCTIONS / INSTRUCTIONS / HINWEISE / INSTRUCCIONES

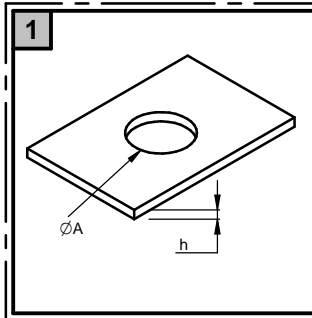

Art.	φ A	h
WARP (2W)	29mm	8-20mm
WARP (8W)	65mm	2-20mm
WARP (15W)	92mm	2-20mm
WARP (25W)	127mm	2-20mm
WARP-Y (8W)	64mm	2-20mm
WARP-Y (15W)	92mm	2-20mm
WARP-Y (25W)	127	2-20mm
VOS (6-8W)	64mm	5-20mm
VOS (15W)	95mm	2-20mm
VOS (25W)	121mm	2-20mm

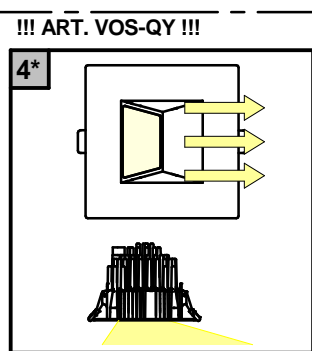
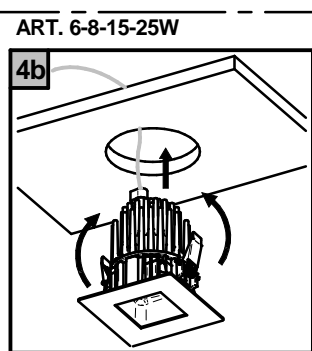
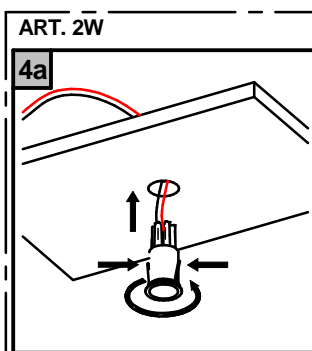
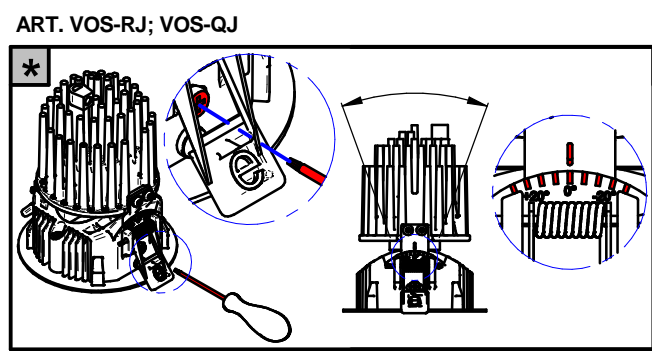
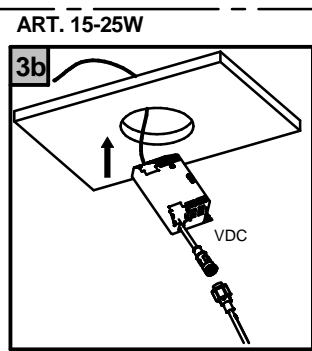
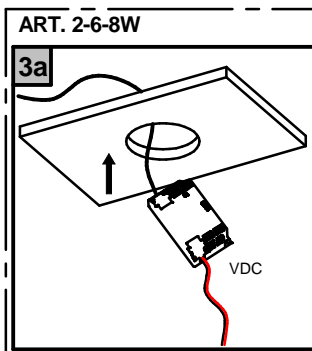
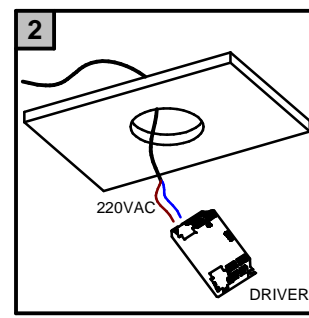

Etichetta energetica scaricabile dal sito www.linealight.com
Energy label downloaded from the website www.linealight.com

ART. 6-8-15-25W

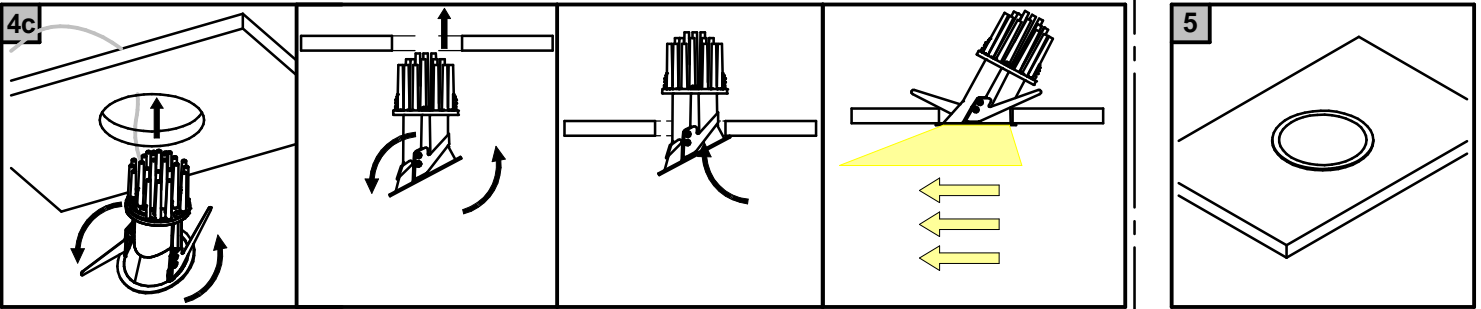

I	GB	F	D	E
<p>Procedura di cablaggio</p> <ol style="list-style-type: none"> 1 Chiudere l' interruttore generale OFF 2 Collegare i faretti all' alimentatore 3 Collegare l' alimentatore alla rete 4 Aprire l' interruttore generale ON 	<p>Wiring procedure</p> <ol style="list-style-type: none"> 1 Switch off the main switch OFF 2 Connect the spotlights to the power supply unit. 3 Connect the power supply unit to the network 4 Switch on the main switch ON 	<p>Procédure de câblage</p> <ol style="list-style-type: none"> 1 Couper le disjoncteur OFF 2 Relier les spots au driver 3 Relier le driver au réseau 4 Connecter le disjoncteur ON 	<p>Anleitung zur Verkabelung</p> <ol style="list-style-type: none"> 1 Schalten Sie den Hauptschalter aus OFF 2 Schliessen Sie die Strahler an dem Stromversorgungsgeraet an 3 Schliessen Sie das Stromversorgungsgeraet ans Netz an 4 Schalten Sie den Hauptschalter ein ON 	<p>Procedimiento de cableado</p> <ol style="list-style-type: none"> 1 Cerrar el interruptor general OFF 2 Conectar los focos al alimentador 3 Conectar el alimentador a la red 4 Abrir el interruptor general ON
<p>N.B Tutte le operazioni di manutenzione ed installazione vanno eseguite con l' interruttore generale in posizione OFF</p> <p>E' possibile collegare più articoli in parallelo all' uscita dello stesso alimentatore</p> <p>I faretti necessitano di tensione costante stabilizzata</p> <p>Per la potenza massima collegabile all'alimentatore seguire le indicazioni sull'etichetta dello stesso</p> <p>IL FARETTO RISULTA GARANTITO SOLO CON ALIMENTATORI DISTRIBUITI DA i-Led</p>	<p>N.B All the maintenance and installation procedures must be carried out with the main switch in position OFF</p> <p>It's possible to connect many parallel spotlights to the output of the same power supply unit</p> <p>Use stabilized constant voltage for the spotlights</p> <p>Follow the instructions on the label of the power supply unit for the maximum power of spotlights that can be connected to it</p> <p>SPOTLIGHTS ARE GUARANTEED ONLY IF POWER SUPPLY UNITS DISTRIBUTED BY i-Led ARE USED</p>	<p>N.B. Toutes les opérations de maintenance et d'installation seront effectuées avec le disjoncteur sur la position OFF</p> <p>Il est possible relier plusieurs spots en parallèle sur la sortie du même driver</p> <p>Les spots nécessitent d'un tension constant stabilisé</p> <p>Pour la puissance maximale reliables au driver, suivre les indications reportées sur son étiquette</p> <p>LE SPOT EST GARANTI SEULEMENT AVEC LES DRIVERS DISTRIBUES PAR i-Led</p>	<p>N.B Die Wartungs - und Instandhaltungsvorgänge müssen mit Hauptschalter in Position durchgeführt werden OFF</p> <p>Sie können mehrere Produkte parallel an den gleichen Netzteil verbinden.</p> <p>Die Licher erfordern konstante stabilisierte Spannung.</p> <p>Für die maximale Stromversorgung das man an den Netzteil verbinden kann befolgen Sie die Anweisungen auf dem Etikett von dem gleichen.</p> <p>DIE GARANTIE IST GÜLTIG NUR FÜR STRAHLER, DIE MIT i-Led STROMVERSORUNGSGERÄTEN EINGESPEIST WERDEN.</p>	<p>N.B Todas las operaciones de mantenimiento e instalación se tendrán que llevar a cabo con el interruptor general en posición OFF</p> <p>Es posible conectar má focos en paralelo a la salida del mismo alimentador</p> <p>Los focos necesitan voltaje constante estabilizada</p> <p>Sobre la potencia máxima conectables al alimentador seguir las indicaciones indicadas en la etiqueta del mismo</p> <p>EL FOCO SÓLO ESTÁ GARANTIZADO CON ALIMENTADORES DISTRIBUIDOS POR i-Led</p>

(ITA) - I prodotti devono essere installati tassativamente con alimentazioni, cablaggi e accessori originali del Gruppo Linea Light, o eventualmente approvati dall'azienda. L'utilizzo di accessori non originali, o non approvati, determina il decadimento di ogni garanzia sul prodotto. **(ENG)** - All power supply, wiring and accessories used for product installation shall be original Linea Light Group parts or approved by the company. The warranty will become void if non original or non approved parts are used. **(FRA)** - Les produits doivent impérativement être installés avec des alimentations, des câblages et des accessoires Linea Light Group, ou qui ont été approuvés par l'entreprise. L'utilisation d'accessoires non d'origine, ou non approuvés, entraîne la déchéance de toute garantie sur le produit. **(ESP)** - Los productos se han de instalar obligatoriamente con alimentaciones, cableados y accesorios originales de Linea Light Group o, de otra forma, deben ser aprobados por la empresa misma. El uso de accesorios no originales, o no aprobados, anula todas las garantías del producto. **(GER)** Die Produkte müssen obligatorisch mit Originalstromversorgung, Originalkabeln und Originalzubehör der Linea Light Group oder mit Teilen, die von der Linea Light Group ausdrücklich empfohlen sind, installiert werden. Die Verwendung von nicht originale oder nicht vom Hersteller empfohlenem Zubehör führt zu einem sofortigen Verfall vom Garantieanspruch für das Produkt.

ART. 2-6-8W:

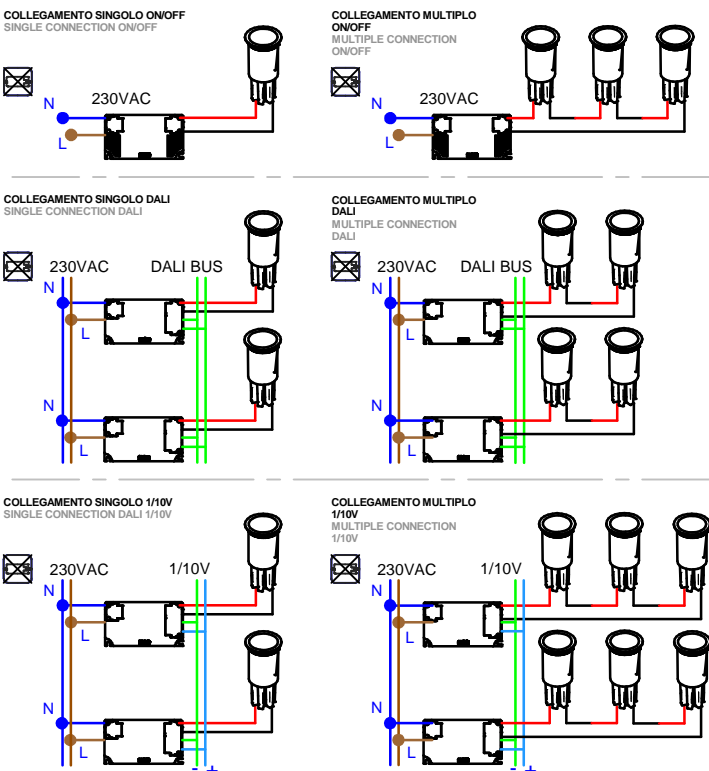

ART. 15-25W

