

Pound_Shaper

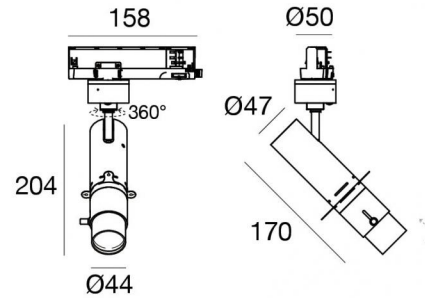

Projectors | 198-264 V
1 arrayLED 10.8 W DC - 13 W AC | CRI 98
83897M66



Technical data	
Type	Track
Installation position	Ceiling
Installation environment	Indoor
Light Source	LED
Circuit structure	arrayLED
Optics	Shaper Medium Distance
Light emission direction	frontal
Nominal power	10.8 W DC
Total Power	13 W
Source lumens	1019 lm
Nominal input voltage	220 - 240 V AC
Input voltage range	198 - 264 V AC
Frequency	50 - 60 Hz
CCT / Tone	2700 K
Colour rendering index	98 Ra
C.C. / C.V.	AC
Safety class	2
IP	IP20
Glow wire test	850°
Direct mounting on normally flammable surfaces	Yes
CE	Yes
Driver included	Driver
Dimmable article	Bluetooth
Directional	Swivelling
total angle (vertical plane)	90 °
total angle (horizontal plane)	360 °
Tilting	No
Walk-over	No
Drive-over	No
Cable included	No
Resin potting	No
Type of light emission	Single emission
Net weight	0.53 Kg
Electrostatic discharge protection	Yes
Surge protection	2 KV

Finishing casing	
Material	Die-cast Aluminium EN AB - 46100
Colour	White
Processing	Powder coating

Technology Partner
SILVAIR

Projectors | 198-264 V | 1 arrayLED 10.8 W DC - 13 W AC | CRI 98
83897M66

Single emission projectors for indoor application. The super warm white LED light source with a shaper medium distance light distribution is composed of 1 arrayed LEDs with CCT of 2700 K and a CRI 98; the source luminous flux is 1019 lm, with a 94.4 lm/W nominal luminous efficacy.

The device body is made of die-cast aluminium en ab - 46100 and features a white finish, processed by means of powder coating. The ingress protection degree is IP20; the total weight is of 0.53 kg.

The total absorbed power is 13 W.

The device features protection class II and can be ceiling-mounted.

Compliant with the EN 60598-1 standard and its specific provisions.

Energy efficiency class

This product contains a light source of energy efficiency class G.

Illuminotechnical Features

Source lumens	1019 lm
Colour temperature	2700 K
Standard Deviation of Colour Matching	2 Step MacAdam
Colour rendering index	98 Ra
Black Body Locus	On
Standard Operating Ambient Temperature	-20 / +50°C
Ordinary temperature on the glass	45°C

LED Life / Failure Ratio

L70 B10 C0 252000h (at Tj 65 Ta 25)

COLOR VECTOR GRAPHIC

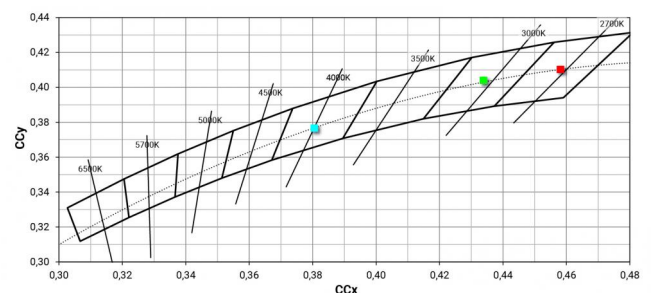
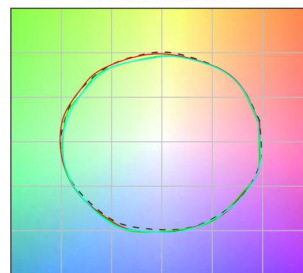

Wiring Diagram

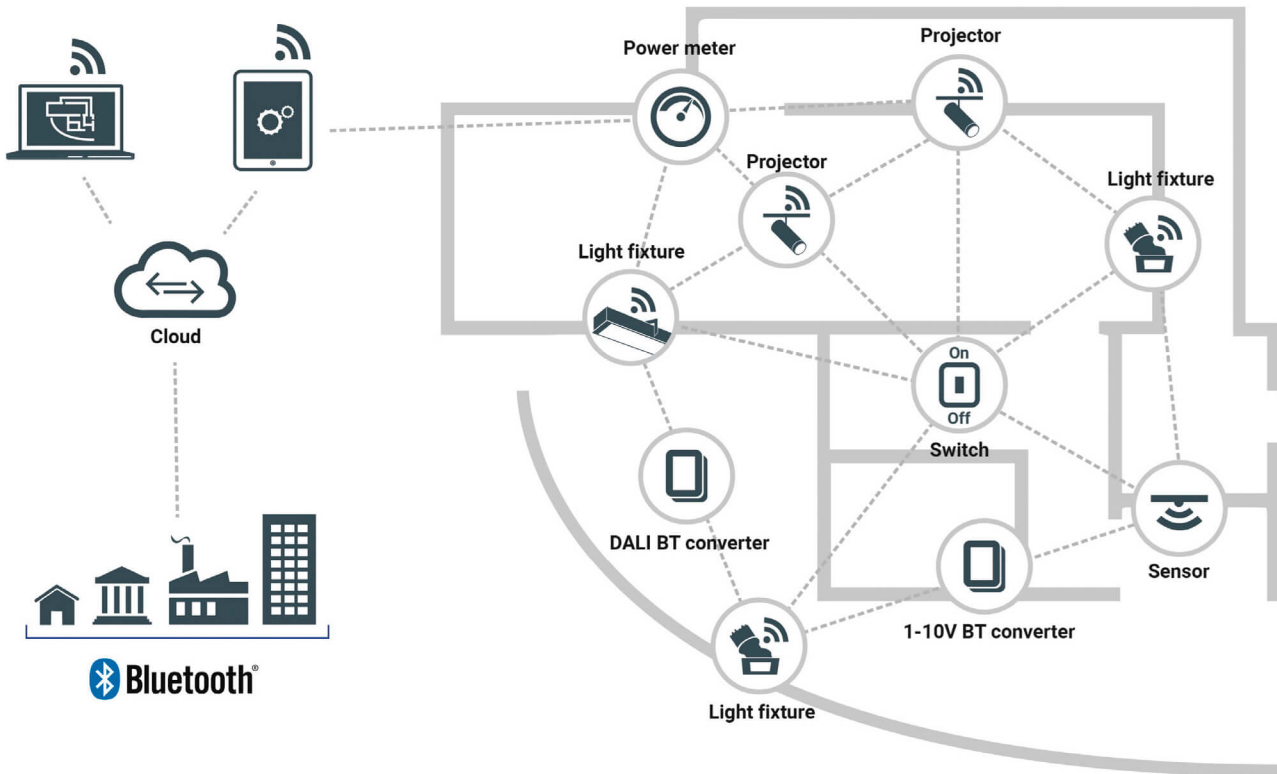

Identify

The first time the device is turned on and every time it gets resetted, the system identify the lamps. The identification consists in an animation called "Attention event" with a 40% dimming for 500ms, 100% dimming for 500ms. The blue status LED blinks during identification too, 500msON/500ms OFF.

Bluetooth - Factory reset for Bluetooth device

A factory reset of the bluetooth device will change the device status in the network mesh from provisioned to not provisioned, all the network settings will be lost. This feature is necessary to reset the connection of a device which cannot be longer controlled. To perform the factory reset action on the device a magnet must be placed on the shown symbol on the box containing the bluetooth module. Keep contact for 5 seconds. Once the factory reset operation is done the system will identify the device.



Antenna

The antenna is incorporated into the article.

LED Blinking

The blue status LED placed on the box containing the Bluetooth interface performs a blink pattern depending on the lamp status.

Quick blinking/slow blinking

The LED blinks fast if the lamp is not connected to the network (every 300ms)
The LED blinks slowly if the lamp is connected to the network (every 2s)

Unprovisioned



Provisioned



Factory Reset

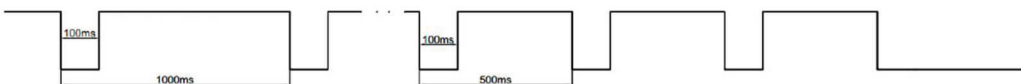

Mesh packet received



Other informations

- If the device is encased in a box, the wireless range may be affected, especially by metallic surfaces. Wireless range must be verified.
- Anunprovisioned device requires 30 seconds to be shown as available to provisioning after turning on
- The device successfully passed the SILVAIR test process
- Supporting EnOcean switch 83017
- Supporting Murata 83016 sensors
- The device can be operated with the SILVAIR app available for Apple phones and tablets
- Check the SILVAIR guide for more informations <https://silvair.com/resources/product-documents/>
- Linea Light has no responsibility for any third party instrument and does not provide any declaration, explicit or implicit, about the availability and/or the performances of said instrument.

POUND_T POUND FOCUS

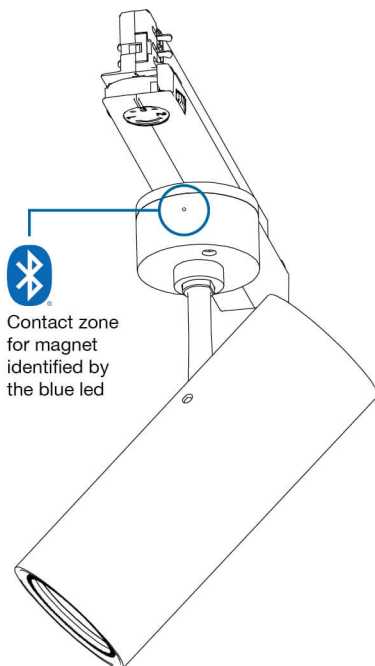

POUND SHAPER

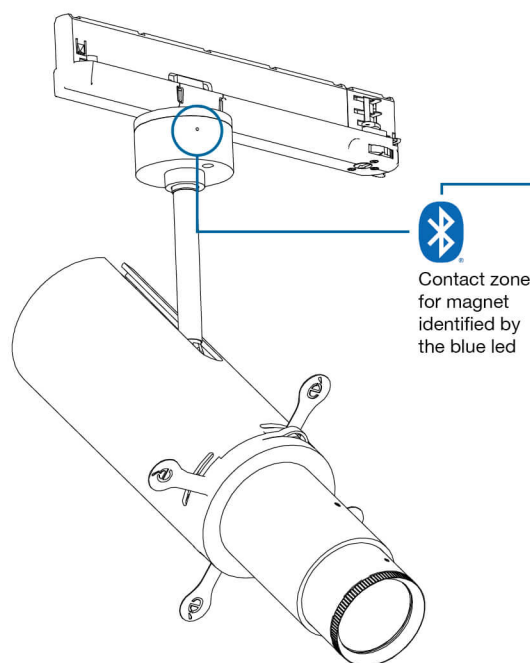

OPTUS_T

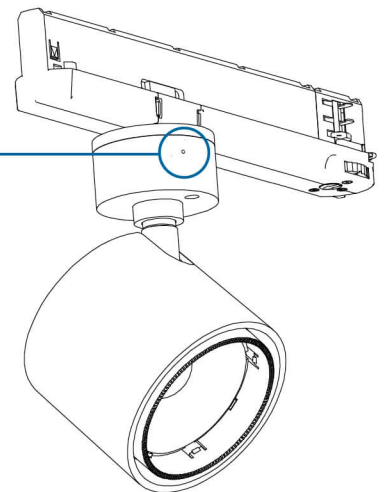

OPTUS_Ww

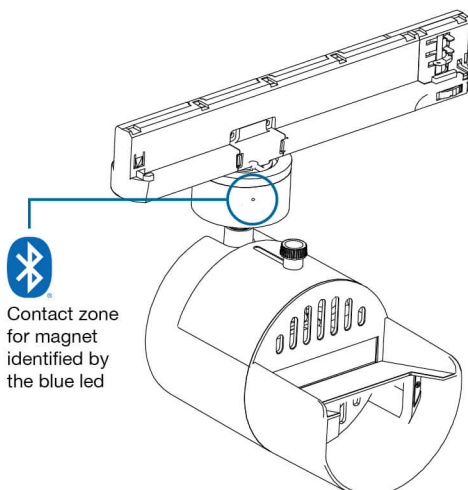

Base NAVATA OPTUS NAVATA POUND SHAPER

